

UNCLASSIFIED

REVISIONS			
DESCRIPTION			DATE
ICD-GPS-200, Revision C, Initial Release			10 October 1993
IRN-200C-001			13 October 1995
IRN-200C-002			25 September 1997
IRN-200C-003			11 October 1999
IRN-200C-004			12 April 2000
IRN-200C-005R1			14 January 2003
DISTRIBUTION STATEMENT A			
APPROVED FOR PUBLIC RELEASE; DISTRIBUTION IS UNLIMITED.			
APPROVALS			
AUTHORIZED SIGNATURES	REPRESENTING		DATE
Signature on file	GPS NAVSTAR JPO SMC/CZ (AFMC)		15 December 1994
Signature on file	ROCKWELL INTERNATIONAL SPACE SYSTEMS DIVISION		16 November 1993
Signature on file	ROCKWELL INTERNATIONAL COLLINS AVIONICS & COMMUNICATIONS DIVISION		15 November 1993
Signature on file	INTERNATIONAL BUSINESS MACHINES (IBM) FEDERAL SYSTEMS COMPANY		02 December 1993
Signature on file *	MARTIN-MARIETTA ASTRO SPACE DIVISION		05 August 1994
* An asterisk affixed to the approval signature indicates that the approval is subject to exceptions taken in the "Letter of Exception" contained in Appendix I of this document.			
INTERFACE CONTROL DOCUMENT			10 Oct 1993
UNLESS OTHERWISE SPECIFIED: DIMENSIONS ARE IN INCHES. TOLERANCES ON: DECIMALS ANGLES XX = ±0.03 ±0° 30' XXX = ±0.01	DR BY		ARINC RESEARCH CORPORATION 2250 E. Imperial Highway, Suite 450 El Segundo, CA 90245-3509
	CHK BY		
THIS DOCUMENT SPECIFIES TECHNICAL REQUIREMENTS AND NOTHING HEREIN CONTAINED SHALL BE DEEMED TO ALTER THE TERMS OF ANY CONTRACT OR PURCHASE ORDER BETWEEN ALL PARTIES AFFECTED.	APPROVALS		ICD TITLE
			Navstar GPS Space Segment / Navigation User Interfaces
			SIZE A
			CODE IDENT NO. 0VYX1
		SCALE: N/A	DRAWING NO. ICD-GPS-200
		REV: C	SHEET i

UNCLASSIFIED

(This page intentionally left blank.)

ICD-GPS-200C
10 OCT 1993

UNCLASSIFIED

UNCLASSIFIED

REVISION RECORD			
LTR	DESCRIPTION	DATE	APPROVED
NC	Initial Release	25 Jan 1983	
A	Incorporates IRN-200NC-001, IRN-200NC-002, and IRN-200NC-003	25 Sep 1984	
B	Incorporates IRN-200A-001A	30 Nov 1987	
C	Incorporates IRN-200B-001 thru IRN-200B-007	10 Oct 1993	
C	Re-formatted in Microsoft Word 6.0 in GEMS compatible format	10 Oct 1993	12 Jan 1996
C	Changed distribution status to Public Release	25 Sep 1997	20 Oct 1997

**IRN-200C-001
ICD-GPS-200C
13 OCT 1995**

UNCLASSIFIED

(This page intentionally left blank.)

ICD-GPS-200C
10 OCT 1993

UNCLASSIFIED

UNCLASSIFIED

Page Revision Record

<u>Pages</u>	<u>Revision</u>	<u>Pages</u>	<u>Revision</u>
i	IRN-200C-005R1	85	IRN-200C-004
ii	Original	86-88	Original
iii	IRN-200C-001	89	IRN-200C-003
iv	Original	90-91	IRN-200C-005R1
v-xvi	IRN-200C-005R1	92-93	IRN-200C-003
1-5	IRN-200C-005R1	94	Original
6	Original	95	IRN-200C-002
7	IRN-200C-005R1	96	Original
8-9	Original	97	IRN-200C-003
9a-9b	IRN-200C-005R1	98	IRN-200C-004
10-10b	IRN-200C-005R1	99-100	Original
11-17	IRN-200C-005R1	101	IRN-200C-004
18-25	Original	102-102b	IRN-200C-003
26	IRN-200C-003	103-104	IRN-200C-005R1
27-32	Original	105-106	Original
32a-32d	IRN-200C-005R1	107	IRN-200C-005R1
33-34	IRN-200C-005R1	108-110	Original
34a-34b	IRN-200C-005R1	111-112	IRN-200C-005R1
35-40	Original	113	IRN-200C-004
41-48	IRN-200C-005R1	114-116	Original
49-50	Original	117-118	IRN-200C-002
51-64	IRN-200C-002	118a	IRN-200C-005R1
64a-64b	IRN-200C-003	118b	IRN-200C-002
64c-64d	IRN-200C-005R1	119	IRN-200C-002
65-66	IRN-200C-005R1	120	IRN-200C-005R1
67-70	IRN-200C-002	121	IRN-200C-001
71	IRN-200C-005R1	122	IRN-200C-004
72-73	IRN-200C-002	123	IRN-200C-005R1
74-75	IRN-200C-003	124	Original
76-76b	IRN-200C-002	125	IRN-200C-005R1
77-79	IRN-200C-005R1	126-128	Original
80	IRN-200C-004	129	IRN-200C-001
81	IRN-200C-005R1	130	IRN-200C-004
82	IRN-200C-004	131-132	IRN-200C-005R1
83-84	Original	133-134	IRN-200C-004

**IRN-200C-005R1
ICD-GPS-200C
14 Jan 2003**

UNCLASSIFIED

<u>Pages</u>	<u>Revision</u>	<u>Pages</u>	<u>Revision</u>
135	IRN-200C-005R1		
136-138	Original		
139-164	IRN-200C-005R1		

**IRN-200C-005R1
ICD-GPS-200C
14 Jan 2003**

TABLE OF CONTENTS

1. SCOPE..... 1

 1.1 Scope 1

 1.2 Key Dates 1

 1.3 ICD Approval and Changes..... 1

2. APPLICABLE DOCUMENTS..... 3

 2.1 Government Documents 3

 2.2 Non-Government Documents..... 3

3. REQUIREMENTS 5

 3.1 Interface Definition 5

 3.2 Interface Identification 5

 3.2.1 Ranging Codes 5

 3.2.1.1 P-Code..... 7

 3.2.1.2 Y-Code 7

 3.2.1.3 C/A-Code 7

 3.2.1.4 L2 CM-Code (IIR-M, IIF, and subsequent blocks)..... 7

 3.2.1.5 L2 CL-Code (IIR-M, IIF, and subsequent blocks)..... 7

 3.2.1.6 Non-standard Codes 7

 3.2.2 NAV Data..... 10

 3.2.3 L1/L2 Signal Structure 10a

 3.3 Interface Criteria..... 11

 3.3.1 Composite Signal 11

 3.3.1.1 Frequency Plan..... 11

 3.3.1.2 Correlation Loss 11

 3.3.1.3 Carrier Phase Noise..... 11

 3.3.1.4 Spurious Transmissions..... 11

 3.3.1.5 Phase Quadrature..... 12

 3.3.1.6 User-Received Signal Levels 12

 3.3.1.7 Equipment Group Delay..... 14

 3.3.1.7.1 Group Delay Uncertainty 14

 3.3.1.7.2 Group Delay Differential 14

 3.3.1.8 Signal Coherence..... 14

 3.3.1.9 Signal Polarization 15

 3.3.2 PRN Code Characteristics 15

 3.3.2.1 Code Structure..... 17

3.3.2.2 P-Code Generation 17

3.3.2.3 C/A-Code Generation..... 28

3.3.2.4 L2 CM-/L2 CL-Code Generation..... 32a

3.3.3 Navigation Data..... 33

 3.3.3.1 Navigation Data Modulation 33

 3.3.3.1.1 Forward Error Correction..... 33

3.3.4 GPS Time and SV Z-Count..... 33

4. NOT APPLICABLE..... 37

5. NOT APPLICABLE..... 39

6. NOTES..... 41

 6.1 Acronyms 41

 6.2 Definitions 43

 6.2.1 User Range Accuracy 43

 6.2.2 SV Block Definitions 43

 6.2.2.1 Developmental SVs..... 43

 6.2.2.2 Operational SVs 43

 6.2.2.2.1 Block II SVs..... 44

 6.2.2.2.2 Block IIA SVs..... 44

 6.2.2.2.3 Block IIR SVs 44

 6.2.2.2.4 Block IIR-M SVs 44

 6.2.2.2.5 Block IIF SVs..... 44

 6.2.3 Operational Interval Definitions..... 44

 6.2.3.1 Normal Operations 44

 6.2.3.2 Short-term Extended Operations 44

 6.2.3.3 Long-term Extended Operations 45

 6.2.4 GPS Week Number 45

 6.2.5 Calendar Year..... 45

 6.2.6 GPS Day..... 45

 6.2.7 L5 Civil Signal 45

 6.3 Supporting Material..... 45

 6.3.1 Received Signals 45

 6.3.2 Extended Navigation Mode (Block II/IIA)..... 47

 6.3.3 Block IIA Mode (Block IIR/IIR-M)..... 48

 6.3.4 Autonomous Navigation Mode 48

10. APPENDIX I. LETTERS OF EXCEPTION..... 49

 10.1 Scope..... 49

10.2 Applicable Documents 49

10.3 Letters of Exception 49

20. APPENDIX II. GPS NAVIGATION DATA STRUCTURE FOR DATA, D(t) 65

20.1 Scope 65

20.2 Applicable Documents. 65

 20.2.1 Government Documents..... 65

 20.2.2 Non-Government Documents..... 65

20.3 Requirements..... 66

 20.3.1 Data Characteristics..... 66

 20.3.2 Message Structure 66

 20.3.3 Message Content 79

 20.3.3.1 Telemetry Word 79

 20.3.3.2 Handover Word (HOW)..... 79

 20.3.3.3 Subframe 1 82

 20.3.3.3.1 Subframe 1 Content..... 82

 20.3.3.3.1.1 Transmission Week Number..... 82

 20.3.3.3.1.2 Code(s) on L2 Channel 83

 20.3.3.3.1.3 SV Accuracy 83

 20.3.3.3.1.4 SV Health..... 84

 20.3.3.3.1.5 Issue of Data, Clock (IODC)..... 85

 20.3.3.3.1.6 Data Flag for L2 P-Code..... 85

 20.3.3.3.1.7 (Reserved)..... 85

 20.3.3.3.1.8 Estimated Group Delay Differential 85

 20.3.3.3.1.9 SV Clock Correction..... 86

 20.3.3.3.2 Subframe 1 Parameter Characteristics 86

 20.3.3.3.3 User Algorithms for Subframe 1 Data 86

 20.3.3.3.3.1 User Algorithm for SV Clock Correction 88

 20.3.3.3.3.2 L1 - L2 Correction 90

 20.3.3.3.3.3 Ionospheric Correction..... 91

 20.3.3.3.3.4 Example Application of Correction Parameters..... 91

 20.3.3.4 Subframes 2 and 3 91

 20.3.3.4.1 Content of Subframes 2 and 3 93

 20.3.3.4.2 Subframe 2 and 3 Parameter Characteristics..... 95

 20.3.3.4.3 User Algorithm for Ephemeris Determination..... 97

 20.3.3.4.3.1 Curve Fit Intervals 97

 20.3.3.4.3.2 Parameter Sensitivity 101

- 20.3.3.4.3.3 Coordinate Systems..... 101
 - 20.3.3.4.3.3.1 ECEF Coordinate System 101
 - 20.3.3.4.3.3.2 Earth-Centered, Inertial (ECI) Coordinate System 102
 - 20.3.3.4.3.4 Geometric Range..... 102
- 20.3.3.4.4 NMCT Validity Time..... 102a
- 20.3.3.5 Subframes 4 and 5 102b
 - 20.3.3.5.1 Content of Subframes 4 and 5 102b
 - 20.3.3.5.1.1 Data ID and SV ID..... 104
 - 20.3.3.5.1.2 Almanac Data..... 106
 - 20.3.3.5.1.3 SV Health..... 109
 - 20.3.3.5.1.4 (Reserved)..... 112
 - 20.3.3.5.1.5 (Reserved)..... 112
 - 20.3.3.5.1.6 Anti-Spoof (A-S) Flags and SV Configurations 112
 - 20.3.3.5.1.7 Almanac Reference Week..... 113
 - 20.3.3.5.1.8 Universal Coordinated Time (UTC) Parameters..... 113
 - 20.3.3.5.1.9 Ionospheric Data 114
 - 20.3.3.5.1.10 Special Messages 117
 - 20.3.3.5.1.11 (Deleted) 118
 - 20.3.3.5.1.12 NMCT 118
 - 20.3.3.5.1.13 Calendar Year Counter..... 118a
 - 20.3.3.5.2 Algorithms Related to Subframe 4 and 5 Data..... 118a
 - 20.3.3.5.2.1 Almanac 118a
 - 20.3.3.5.2.2 Almanac Reference Time..... 121
 - 20.3.3.5.2.3 Almanac Time Parameters 121
 - 20.3.3.5.2.4 Universal Coordinated Time (UTC) 122
 - 20.3.3.5.2.5 Ionospheric Model 125
 - 20.3.3.5.2.6 NMCT Data 125
- 20.3.4 Timing Relationships 129
 - 20.3.4.1 Paging and Cutovers..... 129
 - 20.3.4.2 SV Time vs. GPS Time 129
 - 20.3.4.3 Speed of Light 129
 - 20.3.4.4 Data Sets..... 130
 - 20.3.4.5 Reference Times..... 132
- 20.3.5 Data Frame Parity..... 135
 - 20.3.5.1 SV/CS Parity Algorithm..... 135
 - 20.3.5.2 User Parity Algorithm 135

30. APPENDIX III. GPS NAVIGATION DATA STRUCTURE FOR L2 CNAV DATA, $D_c(t)$ 139

- 30.1 Scope 139
- 30.2 Applicable Documents. 139
 - 30.2.1 Government Documents..... 139
 - 30.2.2 Non-Government Documents..... 139
- 30.3 Requirements..... 140
 - 30.3.1 Data Characteristics..... 140
 - 30.3.2 Message Structure 140
 - 30.3.3 Message Content 140
 - 30.3.3.1 Message Type 1 Clock, Health and Accuracy Parameters..... 147
 - 30.3.3.1.1 Message Type 1 Clock, Health and Accuracy Parameter Content..... 147
 - 30.3.3.1.1.1 Transmission Week Number..... 147
 - 30.3.3.1.1.2 SV Accuracy..... 147
 - 30.3.3.1.1.3 Signal Health (L1/L2/L5)..... 147
 - 30.3.3.1.1.4 Issue of Data, Clock (IODC)..... 148
 - 30.3.3.1.1.4.1 Short-term and Long-term Extended Operations 148
 - 30.3.3.1.1.5 SV Clock Correction..... 148
 - 30.3.3.1.2 Message Type 1 Clock, Health and Accuracy Parameter Characteristics 149
 - 30.3.3.1.3 User Algorithms for Message Type 1 Clock Data 149
 - 30.3.3.2 Message Type 1 and 2 Ephemeris Parameters. 150
 - 30.3.3.2.1 Message Type 1 and 2 Ephemeris Parameter Content 150
 - 30.3.3.2.2 Message Type 1 and 2 Ephemeris Parameter Characteristics 151
 - 30.3.3.2.3 User Algorithm for Ephemeris Determination..... 151
 - 30.3.3.2.3.1 Curve Fit Intervals 151
 - 30.3.3.3 Message Type 3 Parameters 152
 - 30.3.3.3.1 Message Type 3 Parameter Content..... 152
 - 30.3.3.3.1.1 Coordinated Universal Time (UTC) and GPS Time Parameters 152
 - 30.3.3.3.1.2 Ionospheric Data 152
 - 30.3.3.3.1.3 L1/L2 Health..... 152
 - 30.3.3.3.1.4 Estimated L1 – L2 Group Delay Differential..... 153
 - 30.3.3.3.2 Algorithms Related to Message Type 3 Data..... 154
 - 30.3.3.3.2.1 UTC and GPS Time 154
 - 30.3.3.3.2.2 Ionospheric Model 154
 - 30.3.3.3.2.3 Inter-Signal Group Delay Differential Correction 155
 - 30.3.3.3.2.4 L1 /L2 Ionospheric Correction..... 156
 - 30.3.3.4 Message Type 4 Almanac Parameters..... 156

- 30.3.3.4.1 Message Type 4 Almanac Parameter Content..... 156
 - 30.3.3.4.1.1 Almanac Data..... 156
 - 30.3.3.4.1.2 SV Health (L1 and L2)..... 157
 - 30.3.3.4.1.3 Anti-Spoof (A-S) Flags and SV Configurations 157
 - 30.3.3.4.1.4 Almanac Reference Week..... 157
 - 30.3.3.4.1.5 SV PRN Number..... 157
- 30.3.3.4.2 Algorithms Related to Message Type 4 Data..... 157
 - 30.3.3.4.2.1 Almanac 157
 - 30.3.3.4.2.2 Almanac Reference Time..... 157
 - 30.3.3.4.2.3 Almanac Time Parameters..... 157
- 30.3.3.5 Message Type 5..... 158
- 30.3.3.6 Message Type 6 Reduced Almanac Parameters..... 158
 - 30.3.3.6.1 Message Type 6 Reduced Almanac Parameter Content..... 158
 - 30.3.3.6.1.1 Reduced Almanac Data..... 158
 - 30.3.3.6.1.2 Almanac Reference Week..... 158
 - 30.3.3.6.1.3 Almanac Reference Time..... 158
 - 30.3.3.6.2 Reduced Almanac Packet..... 160
 - 30.3.3.6.2.1 SV PRN Number..... 160
 - 30.3.3.6.2.2 Reduced Almanac 160
 - 30.3.3.6.2.3 Signal Health (L1/L2/L5)..... 160
- 30.3.3.7 Message Type 7 Improved Clock, Health and Accuracy Parameters..... 160
 - 30.3.3.7.1 Message Type 7 Improved Clock, Health and Accuracy Parameters Content..... 160
- 30.3.3.8 Message Type 7, 8, and 9 Improved Ephemeris Parameters..... 160
 - 30.3.3.8.1 Message Type 7, 8, and 9 Improved Ephemeris Parameters Content 160
- 30.3.4 Timing Relationships 161
 - 30.3.4.1 Paging and Cutovers..... 161
 - 30.3.4.2 SV Time vs. GPS Time 161
 - 30.3.4.3 Speed of Light..... 161
 - 30.3.4.4 Data Sets..... 161
 - 30.3.4.5 Reference Times..... 161
- 30.3.5 Data Frame Parity..... 162
 - 30.3.5.1 Parity Algorithm..... 162

LIST OF FIGURES

Figure 3-1. Space Vehicle/NAV User Interfaces..... 6

Figure 3-2. Generation of P-, C/A-Codes and Modulating Signals 16

Figure 3-3. X1A Shift Register Generator Configuration..... 18

Figure 3-4. X1B Shift Register Generator Configuration..... 19

Figure 3-5. X2A Shift Register Generator Configuration..... 20

Figure 3-6. X2B Shift Register Generator Configuration..... 21

Figure 3-7. P-Code Generation..... 24

Figure 3-8. P-Code Signal Component Timing 25

Figure 3-9. G1 Shift Register Generator Configuration 29

Figure 3-10. G2 Shift Register Generator Configuration 30

Figure 3-11. C/A-Code Generation 31

Figure 3-12. C/A-Code Timing Relationships..... 32

Figure 3-12A. L2 CM-/L2 CL-Code Timing Relationships 32b

Figure 3-12B. L2 CM/L2 CL Shift Register Generator Configuration 32c

Figure 3-12C. Convolutional Encoder 34a

Figure 3-12D. Convolutional Transmit/Decoding Timing Relationships..... 34a

Figure 3-13. Time Line Relationship of HOW Message 35

Figure 6-1. User Received Minimum Signal Level Variations (Example, Block II/IIA/IIR)..... 46

Figure 10-1. Letter of Exception..... 51

Figure 20-1. Data Format 67

Figure 20-2. TLM and HOW Formats..... 80

Figure 20-3. Sample Application of Correction Parameters..... 92

Figure 20-4. Ionospheric Model 126

Figure 20-5. Example Flow Chart for User Implementation of Parity Algorithm..... 137

Figure 30-1. Message Type 1 Format..... 141

Figure 30-2. Message Type 2 Format..... 142

Figure 30-3. Message Type 3 Format..... 143

Figure 30-4. Message Type 4 Format..... 144

Figure 30-5. Message Type 5 Format..... 145

Figure 30-6. Message Type 6 Format..... 146

Figure 30-7. Reduced Almanac Packet..... 159

UNCLASSIFIED

LIST OF TABLES

Table 3-I.	Code Phase Assignments	8
Table 3-IA.	Code Phase Assignments (IIR-M, IIF, and subsequent blocks only).....	9a
Table 3-IIA.	Signal Configuration	10b
Table 3-II.	Composite L1 Transmitted Signal Phase	13
Table 3-III.	Received Minimum RF Signal Strength	13
Table 3-IV.	P-Code Reset Timing	26
Table 3-V.	Final Code Vector States.....	27
Table 20-I.	Subframe 1 Parameters	87
Table 20-II.	Ephemeris Data Definitions	94
Table 20-III.	Ephemeris Parameters.....	96
Table 20-IV.	Elements of Coordinate Systems	98
Table 20-V.	Data IDs and SV IDs in Subframes 4 and 5	105
Table 20-VI.	Almanac Parameters	108
Table 20-VII.	NAV Data Health Indications	110
Table 20-VIII.	Codes for Health of SV Signal Components.....	111
Table 20-IX.	UTC Parameters.....	115
Table 20-X.	Ionospheric Parameters	116
Table 20-XI.	(Deleted)	119
Table 20-XII.	IODC Values and Data Set Lengths.....	131
Table 20-XIII.	Reference Times	134
Table 20-XIV.	Parity Encoding Equations.....	136
Table 30-I.	Message Type 1 Clock, Health and Accuracy Parameters.....	149
Table 30-II.	Group Delay Differential Parameters.....	153
Table 30-III.	Reduced Almanac Parameters.....	159

**IRN-200C-005R1
ICD-GPS-200C
14 Jan 2003**

UNCLASSIFIED

1. SCOPE

1.1 Scope. This Interface Control Document (ICD) defines the requirements related to the interface between the Space Segment (SS) of the Global Positioning System (GPS) and the Navigation User Segment (US) of the GPS.

1.2 Key Dates. The major milestones for which integration data shall be provided are:

a. (TBD)

1.3 ICD Approval and Changes. ARINC Engineering Services, LLC has been designated the Interface Control Contractor (ICC), and is responsible for the basic preparation, approval, distribution, and retention of the ICD in accordance with YEN 75-13B. The following signatories must approve this ICD to make it effective:

- | | |
|-------------------------------------|---|
| a. Space Segment Contractors | BLOCK II/IIA/IIF
The Boeing Company |
| | Block IIR/IIR-M
Lockheed-Martin Corporation |
| b. Control Segment Contractor | The Boeing Company |
| c. User Segment Contractors | Rockwell International,
Collins Avionics & Communications Division |
| d. Navstar GPS Joint Program Office | SMC/CZ |

IRN-200C-005R1
ICD-GPS-200C
14 Jan 2003

UNCLASSIFIED

Initial signature approval of this ICD can be contingent upon a letter of exception delineating those items by paragraph numbers that are not a part of the approval. Such letters of exception can be prepared by any of the signatories and must be furnished to the ICC for inclusion in Appendix I of the approved and officially released version of the ICD.

Changes to the approved version of this ICD can be initiated by any of the signatories and must be approved by all above signatories. The ICC is responsible for the preparation of the change paper, change coordination, and the change approval by all signatories in accordance with YEN 75-13B. Designated signatories can approve proposed changes to this ICD without any increase in the scope of a specific contract by so specifying in a letter of exception. Such letters of exception must be furnished to the ICC for inclusion in the released version of the approved change and in Appendix I of the subsequent revised issues of the ICD.

Whenever all the issues addressed by a letter of exception are resolved, the respective signatory shall so advise the ICC in writing. When some (but not all) of the exceptions taken by a signatory are resolved, the signatory shall provide the ICC with an updated letter of exception. Based on such notifications -- without processing a proposed interface revision notice (PIRN) for approval -- the ICC will omit the obsolete letter of exception from the next revision of the ICD and will substitute the new one (if required).

Review cycles for all Proposed Interface Revisions Notices (PIRNs) is 45 days after receipt by individual addressees unless a written request for a waiver is submitted to the ICC. Reviewing parties with delinquent responses will be charged with an automatic letter of exception.

**IRN-200C-005R1
ICD-GPS-200C
14 Jan 2003**

2. APPLICABLE DOCUMENTS

2.1 Government Documents. The following documents of the issue specified contribute to the definition of the interfaces between the GPS Space Segment and the GPS Navigation User Segment, and form a part of this ICD to the extent specified herein.

Specifications

Federal

None

Military

None

Other Government Activity

None

Standards

Federal

None

Military

None

Other Publications

YEN 75-13B

Interface Control Working Group Charter

21 Oct 1988

2.2 Non-Government Documents. The following documents of the issue specified contribute to the definition of the interfaces between the GPS Space Segment and the GPS Navigation User Segment and form a part of this ICD to the extent specified herein.

Specifications

None

Other Publications

None

(This page intentionally left blank.)

3. REQUIREMENTS

3.1 Interface Definition. As shown in Figure 3-1, the interface between the GPS Space Segment (SS) and the GPS navigation User Segment (US) consists of two radio frequency (RF) links: L1 and L2. Utilizing these links, the space vehicles (SVs) of the SS shall provide continuous earth coverage for signals which provide to the US the ranging codes and the system data needed to accomplish the GPS navigation (NAV) mission. These signals shall be available to a suitably equipped user with RF visibility to an SV.

3.2 Interface Identification. The carriers of the L-band links are typically modulated by one or more bit trains, each of which normally is a composite generated by the Modulo-2 addition of a pseudo-random noise (PRN) ranging code and the downlink system data (referred to as NAV data).

3.2.1 Ranging Codes. Three PRN ranging codes are transmitted: the precision (P) code which is the principal NAV ranging code; the Y-code, used in place of the P-code whenever the anti-spoofing (A-S) mode of operation is activated; and the coarse/acquisition (C/A) code which is used primarily for acquisition of the P (or Y) code (denoted as P(Y)). Appropriate code-division-multiplexing techniques allow differentiating between the SVs even though they all transmit at the same L-band frequencies. The SVs will transmit intentionally "incorrect" versions of the C/A and the P(Y) codes where needed to protect the users from receiving and utilizing anomalous NAV signals as a result of a malfunction in the SV's reference frequency generation system. These two "incorrect" codes are termed non-standard C/A (NSC) and non-standard Y (NSY) codes.

For Block IIR-M, IIF, and subsequent blocks of SVs, two additional PRN ranging codes are transmitted. They are the L2 civil-moderate (L2 CM) code and the L2 civil-long (L2 CL) code. The SVs will transmit intentionally "incorrect" versions of the L2 CM and L2 CL codes where needed to protect the users from receiving and utilizing anomalous NAV signals as a result of a malfunction in the SV's reference frequency generation system. These "incorrect" codes are termed non-standard L2 CM (NSCM) and non-standard L2 CL (NSCL) codes. The SVs shall also be capable of independently initiating and terminating the broadcast of NSCM and/or NSCL code(s) in response to CS command.

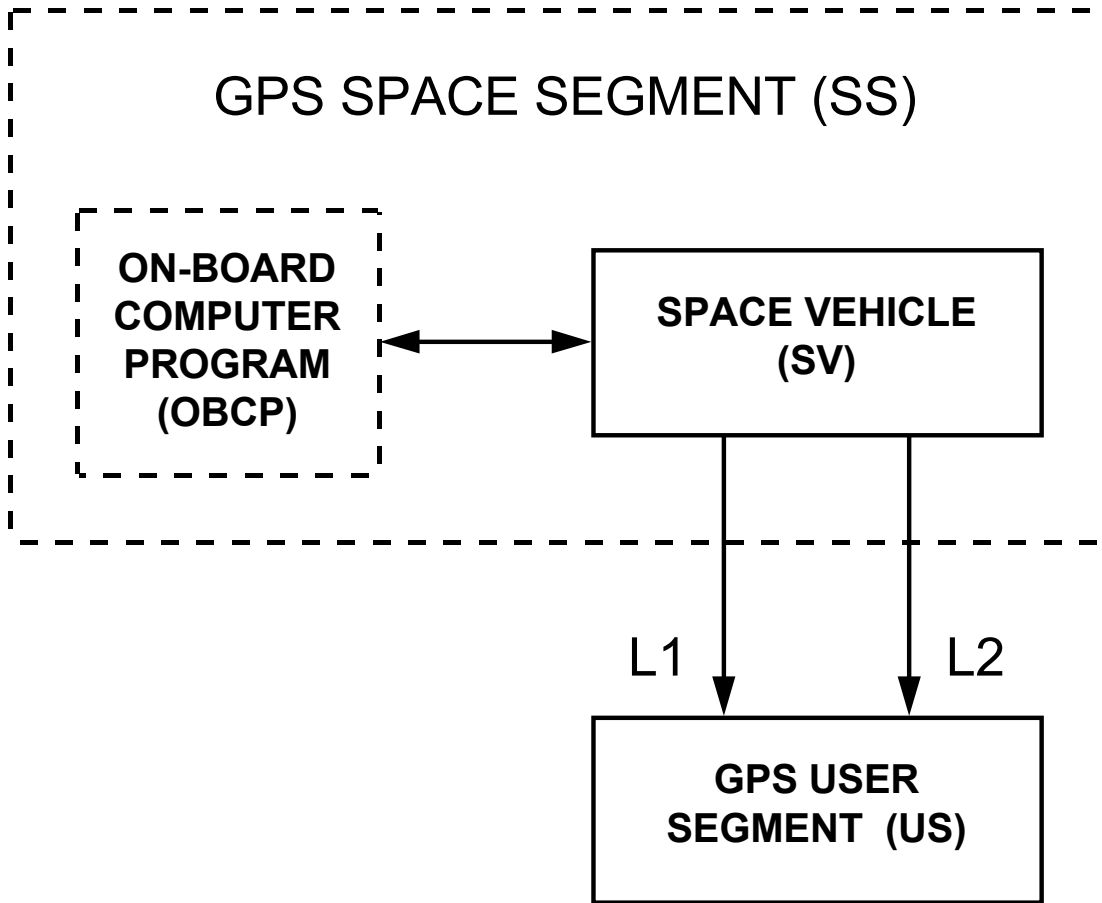

Figure 3-1. Space Vehicle/NAV User Interfaces

3.2.1.1 P-Code. The PRN P-code for SV ID number i is a ranging code, $P_i(t)$, of 7 days in length at a chipping rate of 10.23 Mbps. The 7 day sequence is the Modulo-2 sum of two sub-sequences referred to as $X1$ and $X2_i$; their lengths are 15,345,000 chips and 15,345,037 chips, respectively. The $X2_i$ sequence is an $X2$ sequence selectively delayed by 1 to 37 chips thereby allowing the basic code generation technique to produce a set of 37 mutually exclusive P-code sequences of 7 days in length. Of these, 32 are designated for use by SVs, while the remaining 5 are reserved for other purposes (e.g. ground transmitters, etc.). Assignment of these code phase segments by SV-ID number (or other use) is given in Table 3-I.

3.2.1.2 Y-Code. The PRN Y-code is used in place of the P-code when the A-S mode of operation is activated.

3.2.1.3 C/A-Code. The PRN C/A-Code for SV ID number i is a Gold code, $G_i(t)$, of 1 millisecond in length at a chipping rate of 1023 Kbps. The $G_i(t)$ sequence is a linear pattern generated by the Modulo-2 addition of two sub-sequences, $G1$ and $G2_i$, each of which is a 1023 chip long linear pattern. The epochs of the Gold code are synchronized with the $X1$ epochs of the P-code. As shown in Table 3-I, the $G2_i$ sequence is a $G2$ sequence selectively delayed by 5 to 950 chips, thereby generating a set of 36 mutually exclusive C/A-codes. Assignment of these by GPS PRN Signal Number is given in Table 3-I.

3.2.1.4 L2 CM-Code (IIR-M, IIF, and subsequent blocks). The PRN L2 CM-code for SV ID number i is a ranging code, $C_{M,i}(t)$, which is 20 milliseconds in length at a chipping rate of 511.5 Kbps. The epochs of the L2 CM-code are synchronized with the $X1$ epochs of the P-code. The $C_{M,i}(t)$ sequence is a linear pattern which is short cycled every count of 10230 chips by resetting with a specified initial state. Assignment of initial states by GPS PRN Signal Number is given in Table 3-IA.

3.2.1.5 L2 CL-Code (IIR-M, IIF, and subsequent blocks). The PRN L2 CL-code for SV ID number i is a ranging code, $C_{L,i}(t)$, which is 1.5 seconds in length at a chipping rate of 511.5 Kbps. The epochs of the L2 CL-code are synchronized with the $X1$ epochs of the P-code. The $C_{L,i}(t)$ sequence is a linear pattern which is generated using the same code generator polynomial as the one used for $C_{M,i}(t)$. However, the $C_{L,i}(t)$ sequence is short cycled by resetting with a specified initial state every code count of 767250 chips. Assignment of initial states by GPS PRN Signal Number is given in Table 3-IA.

3.2.1.6 Non-standard Codes. The NSC, NSCM, NSCL, and NSY codes, used to protect the user from a malfunction in the SV's reference frequency system (reference paragraph 3.2.1), are not for utilization by the user and, therefore, are not defined in this document.

UNCLASSIFIED

Table 3-I. Code Phase Assignments (sheet 1 of 2)							
SV ID No.	GPS PRN Signal No.	Code Phase Selection		Code Delay Chips		First 10 Chips Octal* C/A	First 12 Chips Octal P
		C/A(G _{2i})	(X _{2i})	C/A	P		
1	1	2 ⊕ 6	1	5	1	1440	4444
2	2	3 ⊕ 7	2	6	2	1620	4000
3	3	4 ⊕ 8	3	7	3	1710	4222
4	4	5 ⊕ 9	4	8	4	1744	4333
5	5	1 ⊕ 9	5	17	5	1133	4377
6	6	2 ⊕ 10	6	18	6	1455	4355
7	7	1 ⊕ 8	7	139	7	1131	4344
8	8	2 ⊕ 9	8	140	8	1454	4340
9	9	3 ⊕ 10	9	141	9	1626	4342
10	10	2 ⊕ 3	10	251	10	1504	4343
11	11	3 ⊕ 4	11	252	11	1642	
12	12	5 ⊕ 6	12	254	12	1750	
13	13	6 ⊕ 7	13	255	13	1764	
14	14	7 ⊕ 8	14	256	14	1772	
15	15	8 ⊕ 9	15	257	15	1775	
16	16	9 ⊕ 10	16	258	16	1776	
17	17	1 ⊕ 4	17	469	17	1156	
18	18	2 ⊕ 5	18	470	18	1467	
19	19	3 ⊕ 6	19	471	19	1633	
19	19	3 ⊕ 6	19	471	19	1633	

* In the octal notation for the first 10 chips of the C/A code as shown in this column, the first digit (1) represents a "1" for the first chip and the last three digits are the conventional octal representation of the remaining 9 chips. (For example, the first 10 chips of the C/A code for PRN Signal Assembly No. 1 are: 1100100000).

** C/A codes 34 and 37 are common.

*** PRN sequences 33 through 37 are reserved for other uses (e.g. ground transmitters).

⊕ = "exclusive or"

NOTE: The code phase assignments constitute inseparable pairs, each consisting of a specific C/A and a specific P code phase, as shown above.

UNCLASSIFIED

Table 3-I. Code Phase Assignments (sheet 2 of 2)								
SV ID No.	GPS PRN Signal No.	Code Phase Selection		Code Delay Chips		First 10 Chips Octal* C/A	First 12 Chips Octal P	
		C/A(G _{2i})	(X _{2i})	C/A	P			
20	20	4 ⊕ 7	20	472	20	1715	4343	
21	21	5 ⊕ 8	21	473	21	1746		
22	22	6 ⊕ 9	22	474	22	1763		
23	23	1 ⊕ 3	23	509	23	1063		
24	24	4 ⊕ 6	24	512	24	1706		
25	25	5 ⊕ 7	25	513	25	1743		
26	26	6 ⊕ 8	26	514	26	1761		
27	27	7 ⊕ 9	27	515	27	1770		
28	28	8 ⊕ 10	28	516	28	1774		
29	29	1 ⊕ 6	29	859	29	1127		
30	30	2 ⊕ 7	30	860	30	1453		
31	31	3 ⊕ 8	31	861	31	1625		
32	32	4 ⊕ 9	32	862	32	1712		
***	33	5 ⊕ 10	33	863	33	1745		
***	34**	4 ⊕ 10	34	950	34	1713		
***	35	1 ⊕ 7	35	947	35	1134		
***	36	2 ⊕ 8	36	948	36	1456		
***	37**	4 ⊕ 10	37	950	37	1713		
<p>* In the octal notation for the first 10 chips of the C/A code as shown in this column, the first digit (1) represents a "1" for the first chip and the last three digits are the conventional octal representation of the remaining 9 chips. (For example, the first 10 chips of the C/A code for PRN Signal Assembly No. 1 are: 1100100000).</p> <p>** C/A codes 34 and 37 are common.</p> <p>*** PRN sequences 33 through 37 are reserved for other uses (e.g. ground transmitters).</p> <p>⊕ = "exclusive or"</p>								
<p>NOTE: The code phase assignments constitute inseparable pairs, each consisting of a specific C/A and a specific P code phase, as shown above.</p>								

Table 3-IA. Code Phase Assignments (IIR-M, IIF, and subsequent blocks only) (sheet 1 of 2)					
SV ID No.	GPS PRN Signal No.	Initial Shift Register State (Octal)		End Shift Register State (Octal)	
		L2 CM	L2 CL	L2 CM *	L2 CL **
1	1	742417664	624145772	552566002	267724236
2	2	756014035	506610362	034445034	167516066
3	3	002747144	220360016	723443711	771756405
4	4	066265724	710406104	511222013	047202624
5	5	601403471	001143345	463055213	052770433
6	6	703232733	053023326	667044524	761743665
7	7	124510070	652521276	652322653	133015726
8	8	617316361	206124777	505703344	610611511
9	9	047541621	015563374	520302775	352150323
10	10	733031046	561522076	244205506	051266046
11	11	713512145	023163525	236174002	305611373
12	12	024437606	117776450	654305531	504676773
13	13	021264003	606516355	435070571	272572634
14	14	230655351	003037343	630431251	731320771
15	15	001314400	046515565	234043417	631326563
16	16	222021506	671511621	535540745	231516360
17	17	540264026	605402220	043056734	030367366
18	18	205521705	002576207	731304103	713543613
19	19	064022144	525163451	412120105	232674654

* Short cycled period = 10230
 ** Short cycled period = 767250
 *** PRN sequences 33 through 37 are reserved for other uses (e.g. ground transmitters).

NOTE: There are many other available initial register states which can be used for other signal transmitters including any additional SVs in future.

UNCLASSIFIED

Table 3-IA. Code Phase Assignments (IIR-M, IIF, and subsequent blocks only) (sheet 2 of 2)					
SV ID No.	GPS PRN Signal No.	Initial Shift Register State (Octal)		End Shift Register State (Octal)	
		L2 CM	L2 CL	L2 CM *	L2 CL **
20	20	120161274	266527765	365636111	641733155
21	21	044023533	006760703	143324657	730125345
22	22	724744327	501474556	110766462	000316074
23	23	045743577	743747443	602405203	171313614
24	24	741201660	615534726	177735650	001523662
25	25	700274134	763621420	630177560	023457250
26	26	010247261	720727474	653467107	330733254
27	27	713433445	700521043	406576630	625055726
28	28	737324162	222567263	221777100	476524061
29	29	311627434	132765304	773266673	602066031
30	30	710452007	746332245	100010710	012412526
31	31	722462133	102300466	431037132	705144501
32	32	050172213	255231716	624127475	615373171
***	33	500653703	437661701	154624012	041637664
***	34	755077436	717047302	275636742	100107264
***	35	136717361	222614207	644341556	634251723
***	36	756675453	561123307	514260662	257012032
***	37	435506112	240713073	133501670	703702423
* Short cycled period = 10230 ** Short cycled period = 767250 *** PRN sequences 33 through 37 are reserved for other uses (e.g. ground transmitters).					
NOTE: There are many other available initial register states which can be used for other signal transmitters including any additional SVs in future.					

IRN-200C-005R1
ICD-GPS-200C
14 Jan 2003

3.2.2 NAV Data. The NAV data, $D(t)$, includes SV ephemerides, system time, SV clock behavior data, status messages and C/A to P (or Y) code handover information, etc. The 50 bps data is Modulo-2 added to the P(Y)- and C/A- codes; the resultant bit-trains are used to modulate the L1 and L2 carriers. For a given SV, the data train $D(t)$, if present, is common to the P(Y)- and C/A- codes on both the L1 and L2 channels. The content and characteristics of the NAV data, $D(t)$, are given in Appendix II of this document.

For Block IIR-M, the NAV data, $D(t)$, is also Modulo-2 added to the L2 CM-code. However, the NAV data, $D(t)$, can be used in one of two different data rates which are selectable by ground command. $D(t)$ with a data rate of 50 bps can be commanded to be Modulo-2 added to the L2 CM-code, or $D(t)$ with a symbol rate of 50 symbols per second (sps) (rate $\frac{1}{2}$ convolutional encode of a 25 bps NAV data) can be commanded to be Modulo-2 added to the L2 CM-code. The resultant bit-train is combined with L2 CL-code using time-division multiplexing method and the multiplexed bit-trains are used to modulate the L2 carrier.

The above described (and throughout this document) NAV data, $D(t)$, and its modulation onto the L2 CM-code for Block IIR-M may change prior to operational broadcast of L2 C signal.

For Block IIF, and subsequent blocks of SVs, L2 CNAV data, $D_C(t)$, also includes SV ephemerides, system time, SV clock behavior, status messages, etc. The $D_C(t)$ is a 25 bps data stream which is coded by a rate $\frac{1}{2}$ convolutional coder. When selected by ground command, the resulting 50 sps symbol stream is Modulo-2 added to the L2 CM-code; the resultant bit-train is combined with L2 CL-code using time-division multiplexing method; the multiplexed bit-trains are used to modulate the L2 carrier. The content and characteristics of the L2 CNAV data, $D_C(t)$, are given in Appendix III of this document.

3.2.3 L1/L2 Signal Structure. The L1 link consists of two carrier components which are in phase quadrature with each other. Each carrier component is bi-phase shift key (BPSK) modulated by a separate bit train. One bit train is the Modulo-2 sum of the P(Y)-code and NAV data, $D(t)$, while the other is the Modulo-2 sum of the C/A-code and the NAV data, $D(t)$. For Block II/IIA and IIR, the L2 link is BPSK modulated by only one of those two bit trains; the bit train to be used for L2 modulation is selected by ground command. A third modulation mode is also selectable on the L2 channel by ground command: it utilizes the P(Y)-code without the NAV data as the modulating signal. For a particular SV, all transmitted signal elements (carriers, codes and data) are coherently derived from the same on-board frequency source.

For Block IIR-M SVs, the L2 consists of two carrier components. One carrier component is BPSK modulated by the bit train which is the Modulo-2 sum of the P(Y)-code with or without NAV data $D(t)$, while the other is BPSK modulated by any one of four other bit trains which are selectable by ground command. The four possible bit trains are; (1) the Modulo-2 sum of the C/A-code and $D(t)$; (2) the C/A-code with no data; (3) a chip-by-chip time multiplex combination of bit trains consisting of the L2 CM-code with $D(t)$ at 50 bps and the L2 CL-code with no data and; (4) a chip-by-chip time multiplex combination of bit trains consisting of the L2 CM-code with convolutionally encoded $D(t)$ (50 sps) and the L2 CL-code with no data. The L2 CM-code with $D(t)$ is time-multiplexed with L2 CL-code at a 1023 kHz rate. The first L2 CM-code chip starts synchronously with the end/start of week epoch.

For Block IIF, and subsequent blocks of SVs, the L2 consists of two carrier components. One carrier component is BPSK modulated by the bit train which is the Modulo-2 sum of the P(Y)-code with or without NAV data $D(t)$, while the other is BPSK modulated by any one of three other bit trains which are selectable by ground command. The three possible bit trains are; (1) the Modulo-2 sum of the C/A-code and $D(t)$; (2) the C/A-code with no data and; (3) a chip-by-chip time multiplex combination of bit trains consisting of the L2 CM-code with $D_c(t)$ and the L2 CL-code with no data. The L2 CM-code with the 50 sps symbol stream of $D_c(t)$ is time-multiplexed with L2 CL-code at a 1023 kHz rate. The first L2 CM-code chip starts synchronously with the end/start of week epoch.

The different configuration and combination of codes/signals specified in this section are shown in Table 3-IIA.

Table 3-IIA. Signal Configuration				
SV Blocks	L1		L2**	
	In-Phase*	Quadrature-Phase*	In-Phase*	Quadrature-Phase*
Block II/IIA/IIR	$P(Y) \oplus D(t)$	$C/A \oplus D(t)$	$P(Y) \oplus D(t)$ or $P(Y)$ or $C/A \oplus D(t)$	Not Applicable
Block IIR-M***	$P(Y) \oplus D(t)$	$C/A \oplus D(t)$	$P(Y) \oplus D(t)$ or $P(Y)$	$L2\ CM \oplus D(t)$ with $L2\ CL$ or $L2\ CM \oplus D'(t)$ with $L2\ CL$ or $C/A \oplus D(t)$ or C/A
Block IIF	$P(Y) \oplus D(t)$	$C/A \oplus D(t)$	$P(Y) \oplus D(t)$ or $P(Y)$	$L2\ CM \oplus D_c(t)$ with $L2\ CL$ or $C/A \oplus D(t)$ or C/A

Notes: 1) The configuration identified in this table reflects only the content of Section 3.2.3 and does not show all available codes/signals on L1/L2.
 2) It should be noted that there are no flags or bits in the navigation message to directly indicate which signal option is broadcast for L2 Civil (L2 C) signal.

\oplus = “exclusive-or” (modulo-2 addition)
 $D(t)$ = NAV data at 50 bps
 $D'(t)$ = NAV data at 25 bps with FEC encoding resulting in 50 sps
 $D_c(t)$ = L2 CNAV data at 25 bps with FEC encoding resulting in 50 sps

* Terminology of “in-phase” and “quadrature-phase” is used only to identify the relative phase quadrature relationship of the carrier components (i.e. 90 degrees offset of each other).
 ** The two carrier components on L2 may not have the phase quadrature relationship. They may be broadcast on same phase (ref. Section 3.3.1.5).
 *** See paragraph 3.2.2 for Block IIR-M L2 C signal.

3.3 Interface Criteria. The criteria specified in the following define the requisite characteristics of the SS/US interface.

3.3.1 Composite Signal. The following criteria define the characteristics of the composite L-band signals.

3.3.1.1 Frequency Plan. The L-band signals shall be contained within two 20.46-MHz bands centered about L1 and L2. The carrier frequencies for the L1 and L2 signals shall be coherently derived from a common frequency source within the SV. The nominal frequency of this source -- as it appears to an observer on the ground -- is 10.23 MHz. The SV carrier frequency and clock rates -- as they would appear to an observer located in the SV -- are offset to compensate for relativistic effects. The clock rates are offset by $\Delta f/f = -4.4647E-10$, equivalent to a change in the P-code chipping rate of 10.23 MHz offset by a $\Delta f = -4.5674E-3$ Hz. This is equal to 10.22999999543 MHz. The nominal carrier frequencies (f_0) shall be 1575.42 MHz, and 1227.6 MHz for L1 and L2, respectively.

3.3.1.2 Correlation Loss. Correlation loss is defined as the difference between the SV power received in a 20.46 MHz bandwidth and the signal power recovered in an ideal correlation receiver of the same bandwidth. On the L1 and L2 channels, the worst case correlation loss occurs when the carrier is modulated by the sum of the P(Y) code and the NAV data stream. For this case, the correlation loss apportionment shall be as follows:

1. SV modulation imperfections 0.6 dB
2. Ideal UE receiver waveform distortion 0.4 dB
(due to 20.46 MHz filter)

3.3.1.3 Carrier Phase Noise. The phase noise spectral density of the unmodulated carrier shall be such that a phase locked loop of 10 Hz one-sided noise bandwidth shall be able to track the carrier to an accuracy of 0.1 radians rms.

3.3.1.4 Spurious Transmissions. In-band spurious transmissions shall be at least 40 dB below the unmodulated L1 and L2 carriers over the allocated 20.46 MHz channel bandwidth.

3.3.1.5 Phase Quadrature. The two L1 carrier components modulated by the two separate bit trains (C/A-code plus data and P(Y)-code plus data) shall be in phase quadrature (within ± 100 milliradians) with the C/A signal carrier lagging the P signal by 90 degrees. Referring to the phase of the P carrier when $P_i(t)$ equals zero as the "zero phase angle", the P(Y)- and C/A-code generator output shall control the respective signal phases in the following manner: when $P_i(t)$ equals one, a 180-degree phase reversal of the P-carrier occurs; when $G_i(t)$ equals one, the C/A carrier advances 90 degrees; when the $G_i(t)$ equals zero, the C/A carrier shall be retarded 90 degrees (such that when $G_i(t)$ changes state, a 180-degree phase reversal of the C/A carrier occurs). The resultant nominal composite transmitted signal phases as a function of the binary state of only the two modulating signals are as shown in Table 3-II.

For Block IIR-M, IIF, and subsequent blocks of SVs, phase quadrature relationship between the two L2 carrier components can be the same as for the two L1 carrier components as described above. However, for the L2 case, the civil signal carrier component is modulated by any one of three (IIF) or four (IIR-M) different bit trains as described in paragraph 3.2.3. Moreover, the two L2 carrier components can be in same phase. The resultant composite transmitted signal phases will vary as a function of the binary state of the modulating signals as well as the signal power ratio and phase quadrature relationship. Beyond these considerations, additional carrier components in Block IIR-M, IIF, and subsequent blocks of SVs will result in composite transmitted signal phase relationships other than the nominal special case of Table 3-II.

For Block IIF, the crosstalk between the C/A, when selected, and P(Y) signals shall not exceed -20 dB in the L1 and L2. The crosstalk is the relative power level of the undesired signal to the desired reference signal.

3.3.1.6 User-Received Signal Levels. The SV shall provide L1 and L2 navigation signal strength at end-of-life (EOL), worst-case, in order to meet the minimum levels specified in Table 3-III. The minimum received power is measured at the output of a 3 dB_i linearly polarized user receiving antenna (located near ground) at worst normal orientation, when the SV is above a 5-degree elevation angle. The received signal levels are observed within the in-band allocation defined in para. 3.3.1.1.

The Block IIF SV shall provide L1 and L2 signals with the following characteristic: the L1 off-axis power gain shall not decrease by more than 2 dB from the Edge-of-Earth (EOE) to nadir, nor more than 10 dB from EOE to 20 degrees off nadir, and no more than 18 dB from EOE to 23 degrees off nadir; the L2 off-axis power gain shall not decrease by more than 2 dB from EOE to nadir, and no more than 10 dB from EOE to 23 degrees off nadir; the power drop off between EOE and ± 23 degrees shall be in a monotonically decreasing fashion.

Additional related data is provided as supporting material in paragraph 6.3.1.

Table 3-II. Composite L1 Transmitted Signal Phase ** (Block II/IIA and IIR SVs Only)		
Nominal Composite L1 Signal Phase*	Code State	
	P	C/A
0°	0	0
-70.5°	1	0
+109.5°	0	1
180°	1	1

* Relative to 0, 0 code state with positive angles leading and negative angles lagging.
 ** Based on the composite of two L1 carrier components with 3 dB difference in the power levels of the two.

Table 3-III. Received Minimum RF Signal Strength			
SV Blocks	Channel	Signal	
		P(Y)	C/A or L2 C
II/IIA/IIR	L1	-161.5 dBW	-158.5 dBW
	L2	-164.5 dBW	or -164.5 dBW
IIR-M/IIF	L1	-161.5 dBW	-158.5 dBW
	L2	-161.5 dBW	-160.0 dBW

3.3.1.7 Equipment Group Delay. Equipment group delay is defined as the delay between the L-band radiated output of a specific SV (measured at the antenna phase center) and the output of that SV's on-board frequency source; the delay consists of a bias term and an uncertainty. The bias term is of no concern to the US since it is included in the clock correction parameters relayed in the NAV data, and is therefore accounted for by the user computations of system time (reference paragraphs 20.3.3.3.3.1, 30.3.3.3.2.3). The uncertainty (variation) of this delay as well as the group delay differential between the signals of L1 and L2 are defined in the following.

3.3.1.7.1 Group Delay Uncertainty. The effective uncertainty of the group delay shall not exceed 3.0 nanoseconds (two sigma).

3.3.1.7.2 Group Delay Differential. The group delay differential between the radiated L1 and L2 signals (i.e. L1 P(Y) and L2 P(Y), L1 P(Y) and L2 C) is specified as consisting of random plus bias components. The mean differential is defined as the bias component and will be either positive or negative. For a given navigation payload redundancy configuration, the absolute value of the mean differential delay shall not exceed 15.0 nanoseconds. The random variations about the mean shall not exceed 3.0 nanoseconds (two sigma). Corrections for the bias components of the group delay differential are provided to the US in the Nav message using parameters designated as T_{GD} (reference paragraph 20.3.3.3.3.2) and Inter-Signal Correction (ISC) (reference paragraph 30.3.3.3.2.3).

3.3.1.8 Signal Coherence. All transmitted signals for a particular SV shall be coherently derived from the same on-board frequency standard; all digital signals shall be clocked in coincidence with the PRN transitions for the P-signal and occur at the P-signal transition speed. On the L1 channel the data transitions of the two modulating signals (i.e., that containing the P(Y)-code and that containing the C/A-code), L1 P(Y) and L1 C/A, shall be such that the average time difference between the transitions does not exceed 10 nanoseconds (two sigma).

3.3.1.9 Signal Polarization. The transmitted signal shall be right-hand circularly polarized (RHCP). For the angular range of ± 14.3 degrees from boresight, L1 ellipticity shall be no worse than 1.2 dB for Block II/IIA and shall be no worse than 1.8 dB for Block IIR/IIR-M/IIF SVs. L2 ellipticity shall be no worse than 3.2 dB for Block II/IIA SVs and shall be no worse than 2.2 dB for Block IIR/IIR-M/IIF over the angular range of ± 14.3 degrees from boresight.

3.3.2 PRN Code Characteristics. The characteristics of the P-, L2 CM-, L2 CL-, and the C/A-codes are defined below in terms of their structure and the basic method used for generating them. Figure 3-2 depicts a simplified block diagram of the scheme for generating the 10.23 Mbps $P_i(t)$ and the 1.023 Mbps $G_i(t)$ patterns (referred to as P- and C/A-codes respectively), and for Modulo-2 summing these patterns with the NAV bit train, $D(t)$, which is clocked at 50 bps. The resultant composite bit trains are then used to modulate the L-band carriers.

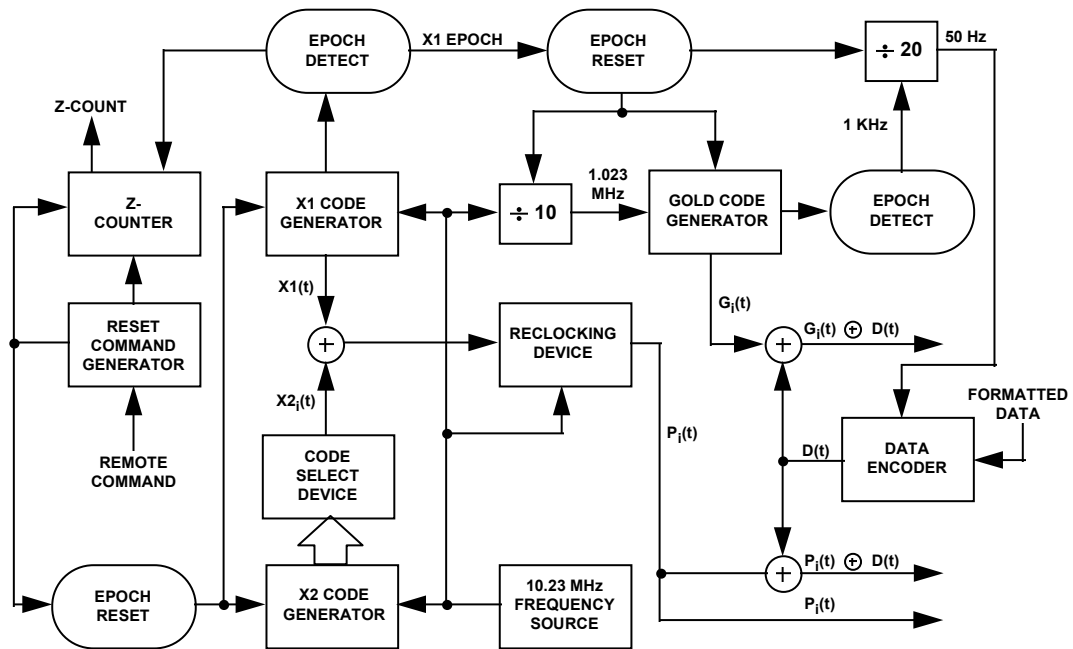

Figure 3-2. Generation of P-, C/A-Codes and Modulating Signals

IRN-200C-005R1
 ICD-GPS-200C
 14 Jan 2003

3.3.2.1 Code Structure. The $P_i(t)$ pattern (P-code) is generated by the Modulo-2 summation of two PRN codes, $X1(t)$ and $X2(t - iT)$, where T is the period of one P-code chip and equals $(1.023 \times 10^7)^{-1}$ seconds, while i is an integer from 1 through 37. This allows the generations of 37 unique $P(t)$ code phases (identified in Table 3-I) using the same basic code generator.

The linear $G_i(t)$ pattern (C/A-code) is the Modulo-2 sum of two 1023-bit linear patterns, $G1$ and $G2_i$. The latter sequence is selectively delayed by an integer number of chips to produce 36 unique $G(t)$ patterns (defined in Table 3-I).

The $C_{M,i}(t)$ pattern (L2 CM-code) is a linear pattern which is reset with a specified initial state every code count of 10230 chips. Different initial states are used to generate different $C_{M,i}(t)$ patterns (defined in Table 3-IA).

The $C_{L,i}(t)$ pattern (L2 CL-code) is also a linear pattern but with a longer reset period of 767250 chips. Different initial states are used to generate different $C_{L,i}(t)$ patterns (defined in Table 3-IA).

For a given SV-ID, two different initial states are used to generate different $C_{L,i}(t)$ and $C_{M,i}(t)$ patterns.

3.3.2.2 P-Code Generation. Each $P_i(t)$ pattern is the Modulo-2 sum of two extended patterns clocked at 10.23 Mbps ($X1$ and $X2_i$). $X1$ itself is generated by the Modulo-2 sum of the output of two 12-stage registers ($X1A$ and $X1B$) short cycled to 4092 and 4093 chips respectively. When the $X1A$ short cycles are counted to 3750, the $X1$ epoch is generated. The $X1$ epoch occurs every 1.5 seconds after 15,345,000 chips of the $X1$ pattern have been generated. The polynomials for $X1A$ and $X1B$, as referenced to the shift register input, are:

$$X1A: 1 + X^6 + X^8 + X^{11} + X^{12}, \text{ and}$$

$$X1B: 1 + X^1 + X^2 + X^5 + X^8 + X^9 + X^{10} + X^{11} + X^{12}.$$

Samples of the relationship between shift register taps and the exponents of the corresponding polynomial, referenced to the shift register input, are as shown in Figures 3-3, 3-4, 3-5 and 3-6.

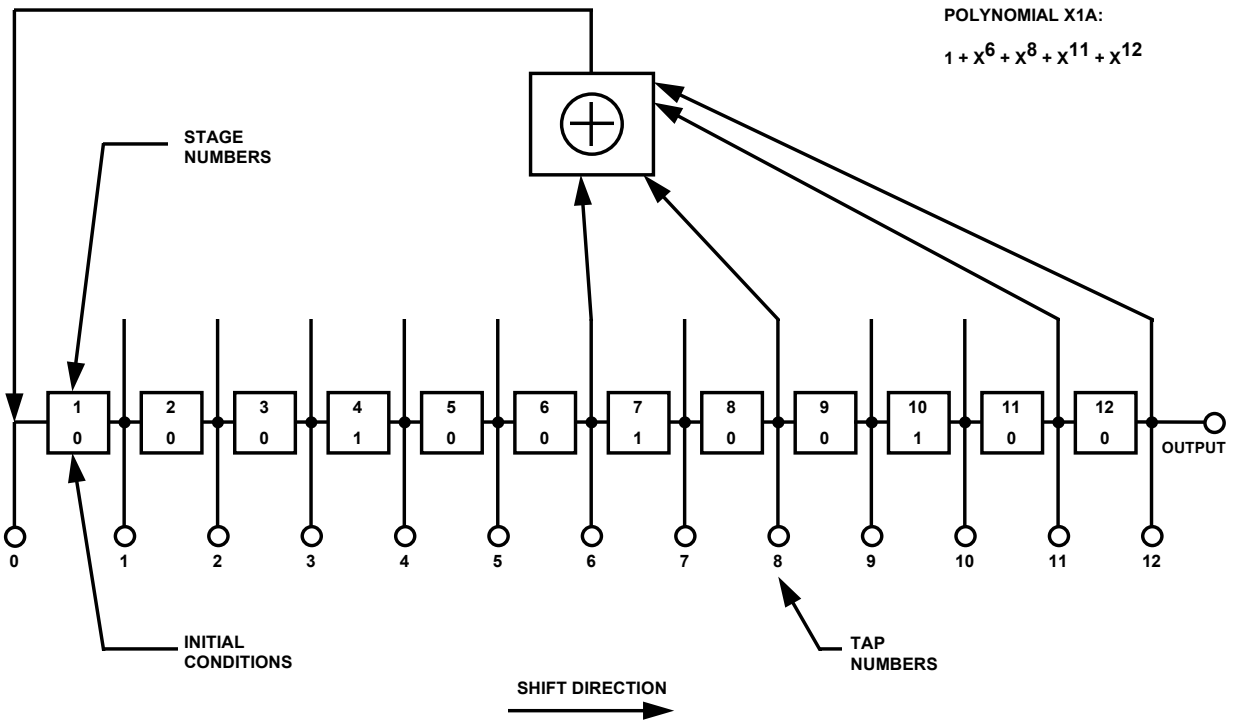

Figure 3-3. X1A Shift Register Generator Configuration

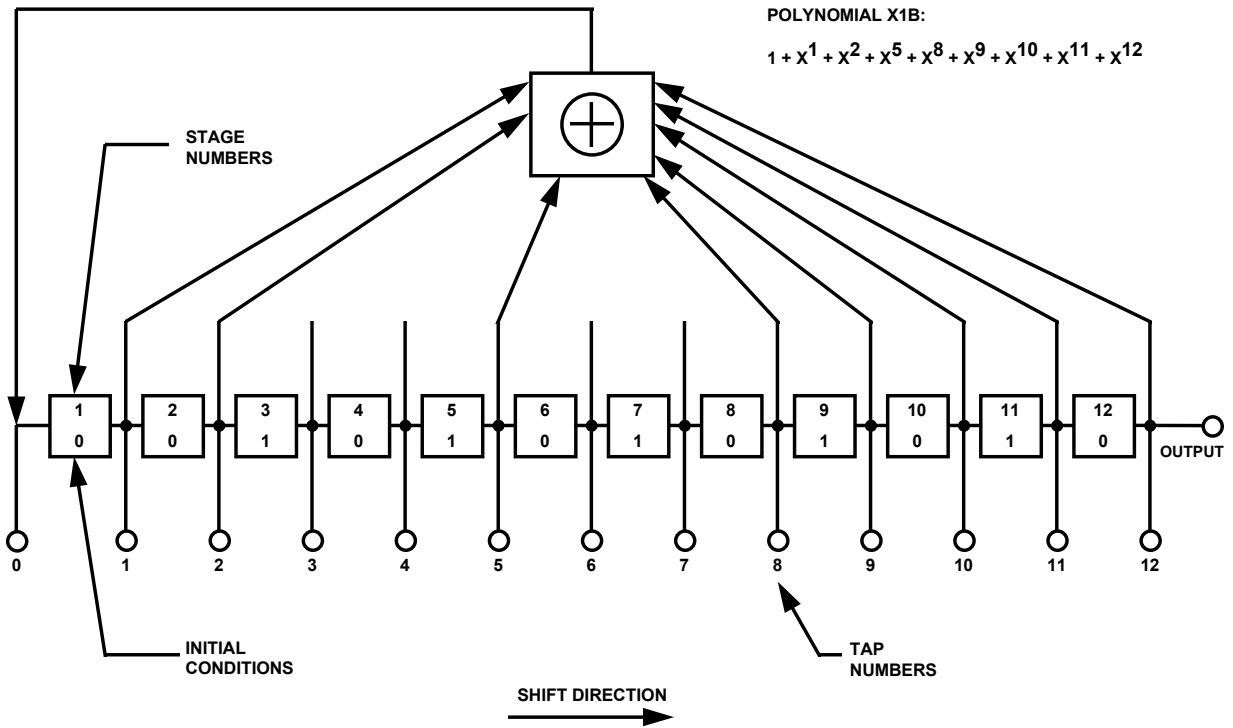

Figure 3-4. X1B Shift Register Generator Configuration

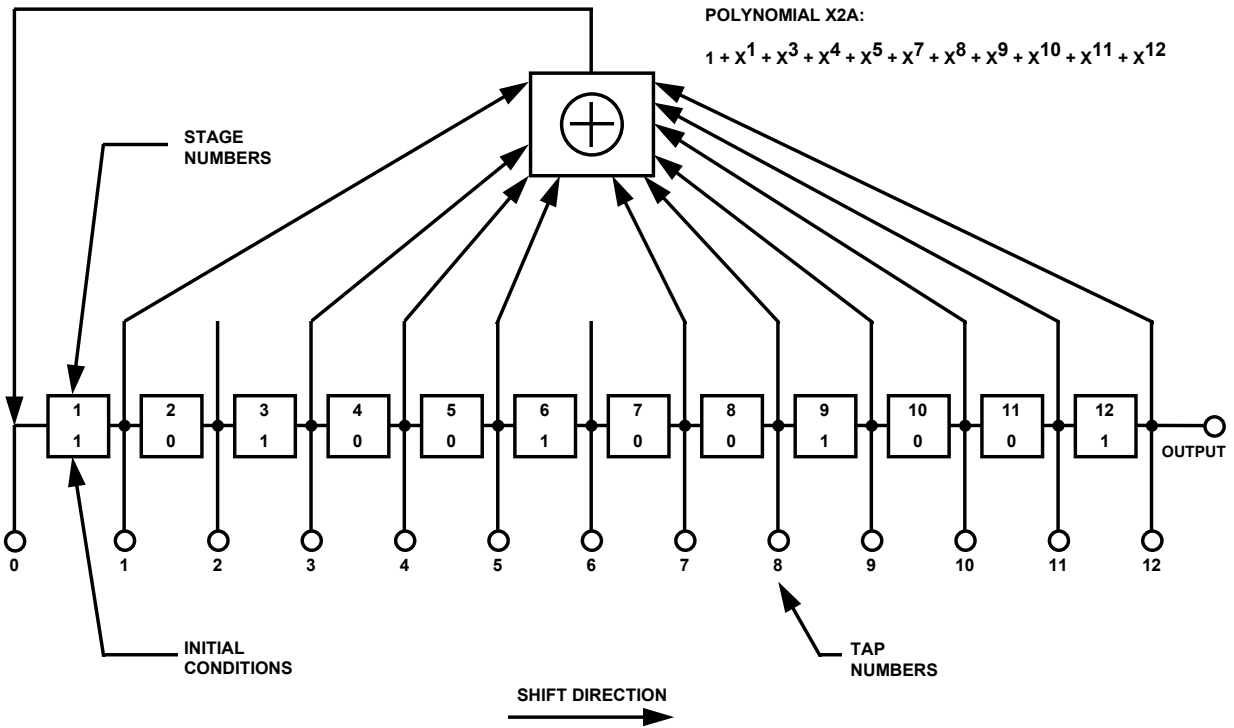

Figure 3-5. X2A Shift Register Generator Configuration

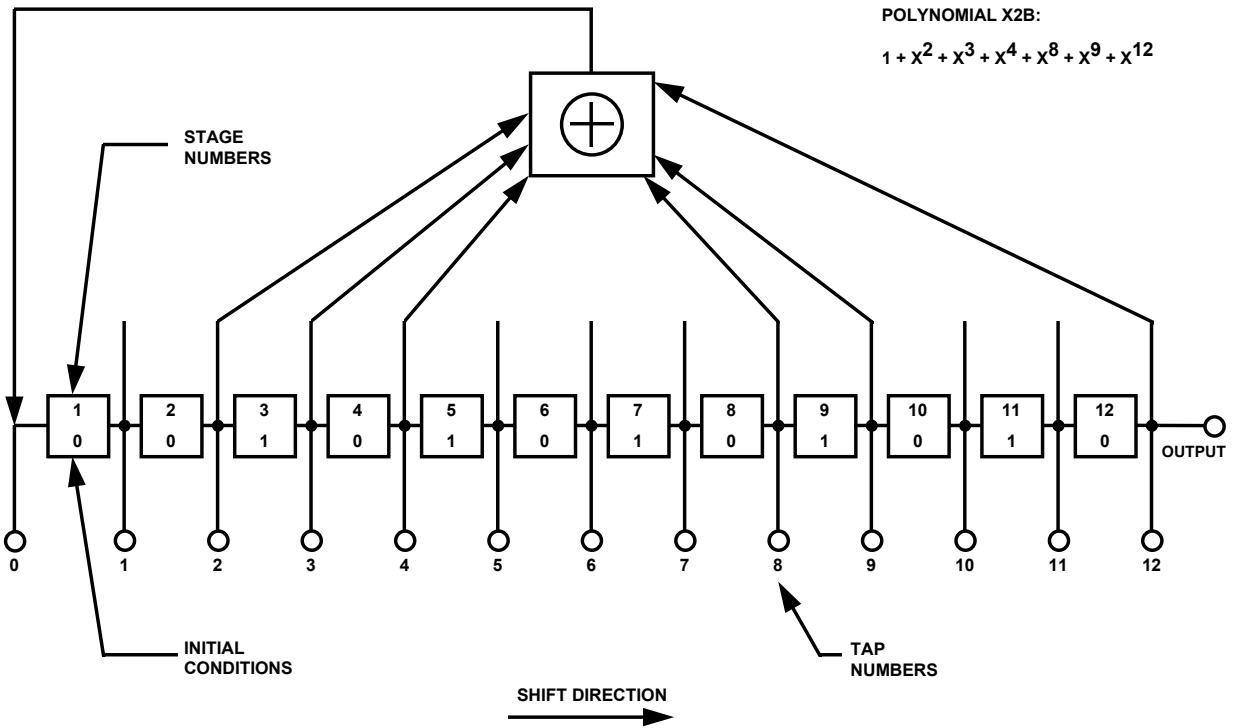

Figure 3-6. X2B Shift Register Generator Configuration

UNCLASSIFIED

The state of each generator can be expressed as a code vector word which specifies the binary sequence constant of each register as follows: (a) the vector consists of the binary state of each stage of the register, (b) the stage 12 value appears at the left followed by the values of the remaining states in order of descending stage numbers, and (c) the shift direction is from lower to higher stage number with stage 12 providing the current output. This code vector convention represents the present output and 11 future outputs in sequence. Using this convention, at each X1 epoch, the X1A shift register is initialized to code vector 001001001000 and the X1B shift register is initialized to code vector 010101010100. The first chip of the X1A sequence and the first chip of the X1B sequence occur simultaneously in the first chip interval of any X1 period.

The natural 4095 chip cycles of these generating sequences are shortened to cause precession of the X1B sequence with respect to the X1A sequence during subsequent cycles of the X1A sequence in the X1 period. Re-initialization of the X1A shift register produces a 4092 chip sequence by omitting the last 3 chips (001) of the natural 4095 chip X1A sequence. Re-initialization of the X1B shift register produces a 4093 chip sequence by omitting the last 2 chips (01) of the natural 4095 chip X1B sequence. This results in the phase of the X1B sequence lagging by one chip for each X1A cycle in the X1 period.

The X1 period is defined as the 3750 X1A cycles (15,345,000 chips) which is not an integer number of X1B cycles. To accommodate this situation, the X1B shift register is held in the final state (chip 4093) of its 3749th cycle. It remains in this state until the X1A shift register completes its 3750th cycle (343 additional chips). The completion of the 3750th X1A cycle establishes the next X1 epoch which re-initializes both the X1A and X1B shift registers starting a new X1 cycle.

The $X2_i$ sequences are generated by first producing an X2 sequence and then delaying it by a selected integer number of chips, i , ranging from 1 to 37. Each of the $X2_i$ sequences is then Modulo-2 added to the X1 sequence thereby producing up to 37 unique $P(t)$ sequences.

ICD-GPS-200C
10 OCT 1993

UNCLASSIFIED

The X2A and X2B shift registers, used to generate X2, operate in a similar manner to the X1A and X1B shift registers. They are short-cycled, X2A to 4092 and X2B to 4093, so that they have the same relative precession rate as the X1 shift registers. X2A epochs are counted to include 3750 cycles and X2B is held in the last state at 3749 cycle until X2A completes its 3750th cycle. The polynomials for X2A and X2B, as referenced to the shift register input, are:

$$\text{X2A: } 1 + X^1 + X^3 + X^4 + X^5 + X^7 + X^8 + X^9 + X^{10} + X^{11} + X^{12}, \text{ and}$$

$$\text{X2B: } 1 + X^2 + X^3 + X^4 + X^8 + X^9 + X^{12}.$$

(The initialization vector for X2A is 100100100101 and for X2B is 010101010100).

The X2A and X2B epochs are made to precess with respect to the X1A and X1B epochs by causing the X2 period to be 37 chips longer than the X1 period. When the X2A is in the last state of its 3750th cycle and X2B is in the last state of its 3749th cycle, their transitions to their respective initial states are delayed by 37 chip time durations.

At the beginning of the GPS week, X1A, X1B, X2A and X2B shift registers are initialized to produce the first chip of the week. The precession of the shift registers with respect to X1A continues until the last X1A period of the GPS week interval. During this particular X1A period, X1B, X2A and X2B are held when reaching the last state of their respective cycles until that X1A cycle is completed (see Table 3-IV). At this point, all four shift registers are initialized and provide the first chip of the new week.

Figure 3-7 shows a functional P-code mechanization. Signal component timing is shown in Figure 3-8, while the end-of-week reset timing and the final code vector states are given in Tables 3-IV and 3-V, respectively.

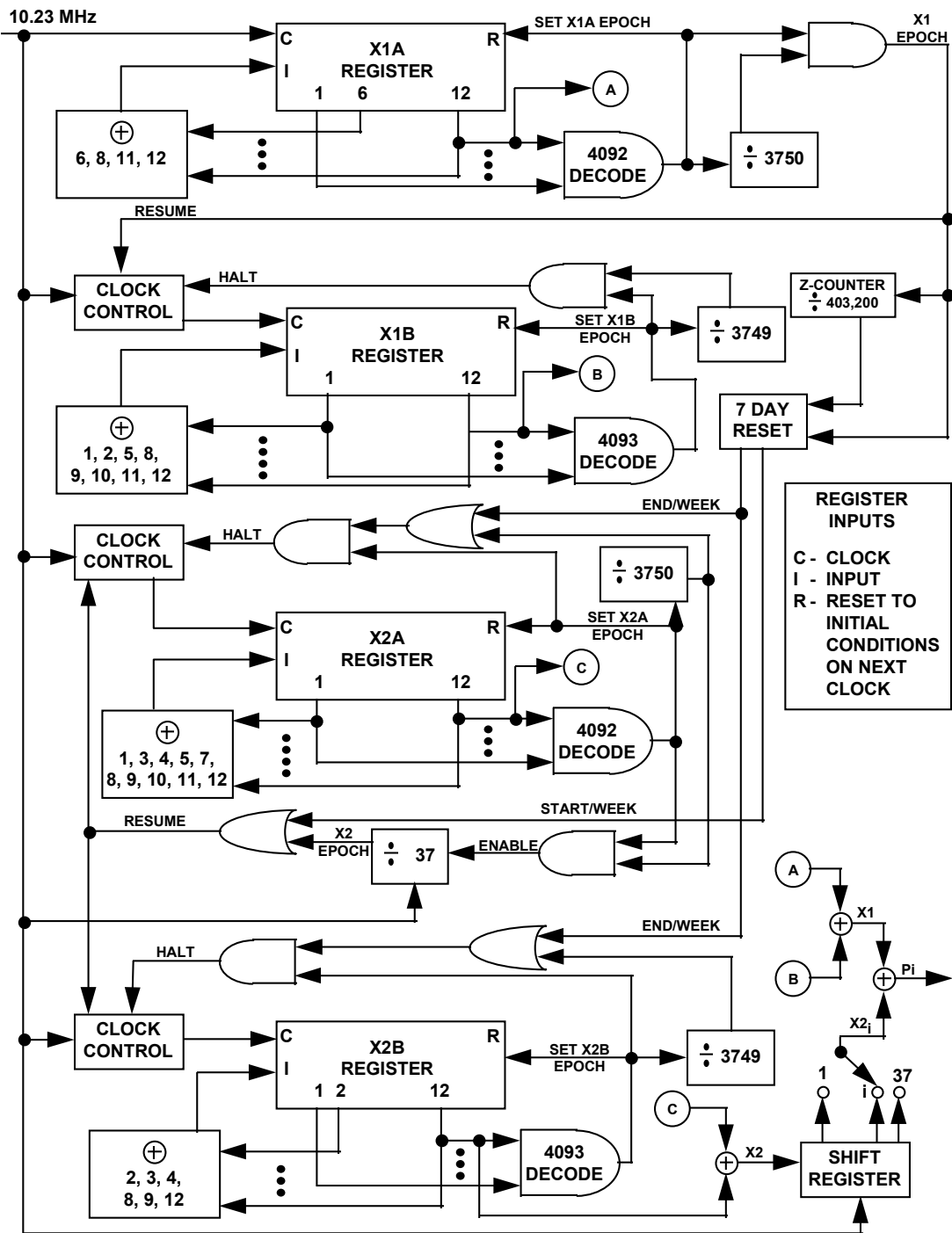

Figure 3-7. P-Code Generation

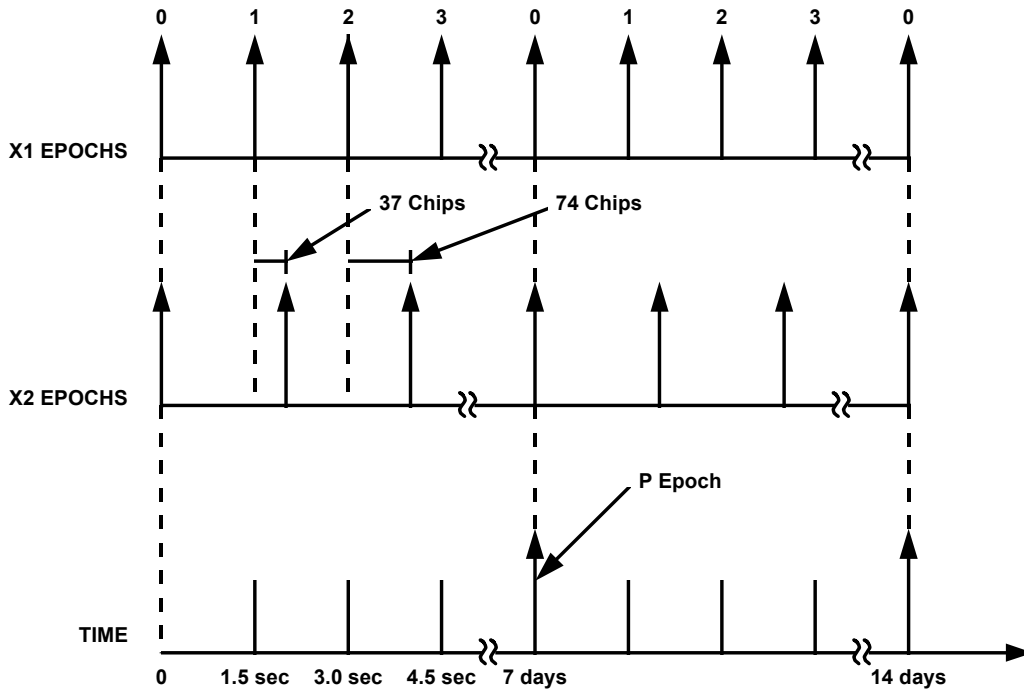



Figure 3-8. P-Code Signal Component Timing

Table 3-IV. P-Code Reset Timing

(Last 400 μ sec of 7-day period)

	Code Chip			
	X1A-Code	X1B-Code	X2A-Code	X2B-Code
TIME 	1	345	1070	967
	•	•	•	•
	•	•	•	•
	•	•	•	•
	3023	3367	4092	3989
	•	•	•	•
	•	•	•	•
	•	•	•	•
	3127	3471	4092	4093
	•	•	•	•
	•	•	•	•
	•	•	•	•
	3749	4093	4092	4093
	•	•	•	•
	•	•	•	•
4092*	4093	4092	4093	

* Last Chip of Week.

Table 3-V. Final Code Vector States			
Code	Chip Number	Vector State	Vector State for 1st Chip following Epoch
X1A	4091	100010010010	001001001000
	4092	000100100100	
X1B	4092	100101010101	010101010100
	4093	001010101010	
X2A	4091	111001001001	100100100101
	4092	110010010010	
X2B	4092	000101010101	010101010100
	4093	001010101010	
NOTE: First Chip in each sequence is output bit whose leading edge occurs simultaneously with the epoch.			

3.3.2.3 C/A-Code Generation. Each $G_i(t)$ sequence is a 1023-bit Gold-code which is itself the Modulo-2 sum of two 1023-bit linear patterns, G_1 and G_{2i} . The G_{2i} sequence is formed by effectively delaying the G_2 sequence by an integer number of chips ranging from 5 to 950. The G_1 and G_2 sequences are generated by 10-stage shift registers having the following polynomials as referred to in the shift register input (see Figures 3-9 and 3-10).

$$G_1 = X^{10} + X^3 + 1, \text{ and}$$
$$G_2 = X^{10} + X^9 + X^8 + X^6 + X^3 + X^2 + 1.$$

The initialization vector for the G_1 and G_2 sequences is 1111111111. The G_1 and G_2 shift registers are initialized at the P-coder X_1 epoch. The G_1 and G_2 registers are clocked at 1.023 MHz derived from the 10.23 MHz P-coder clock. The initialization by the X_1 epoch phases the 1.023 MHz clock to insure that the first chip of the C/A code begins at the same time as the first chip of the P-code.

The effective delay of the G_2 sequence to form the G_{2i} sequence is accomplished by combining the output of two stages of the G_2 shift register by Modulo-2 addition (see Figure 3-11). Thirty-six of the possible combinations are selected, one to correspond to each of the 36 different P-codes. Table 3-1 contains a tabulation of the G_2 shift register taps selected and their corresponding P-code X_{2i} and PRN signal numbers together with the first several chips of each resultant PRN code. Timing relationships related to the C/A code are shown in Figure 3-12.

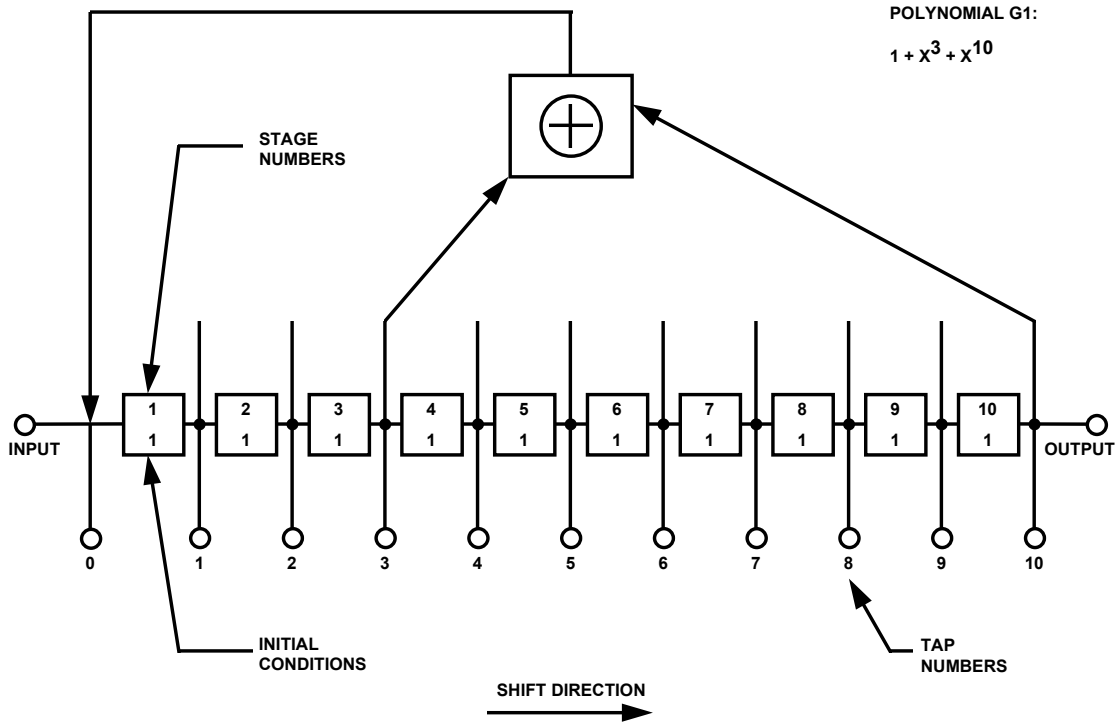

Figure 3-9. G1 Shift Register Generator Configuration

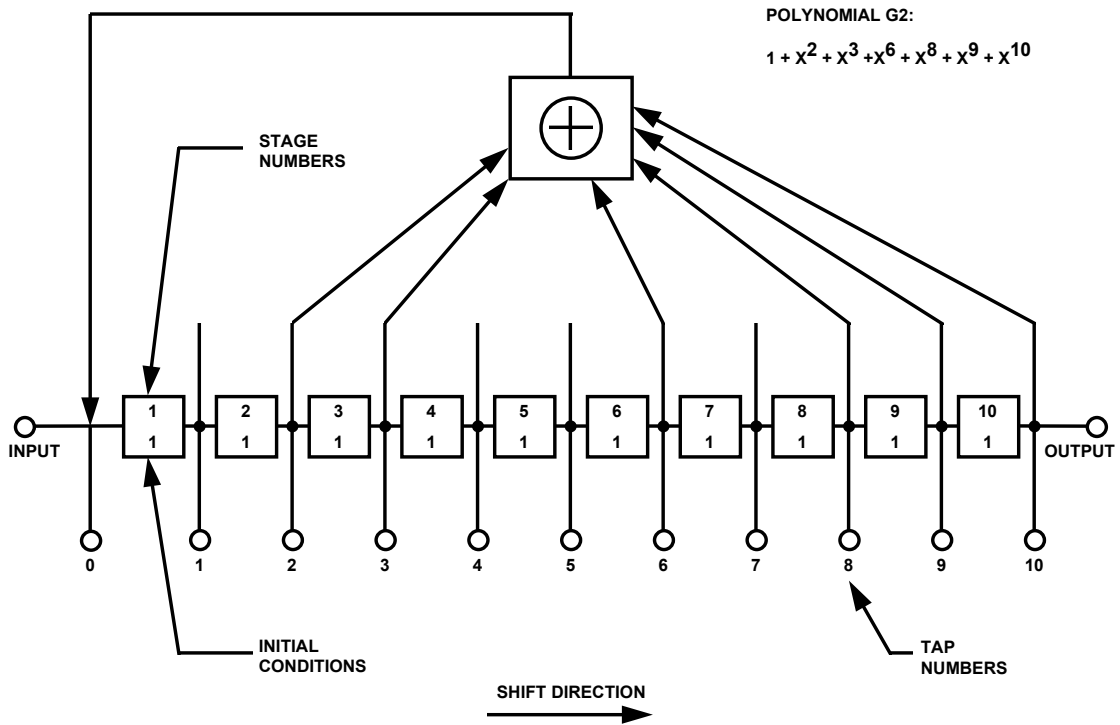

Figure 3-10. G2 Shift Register Generator Configuration

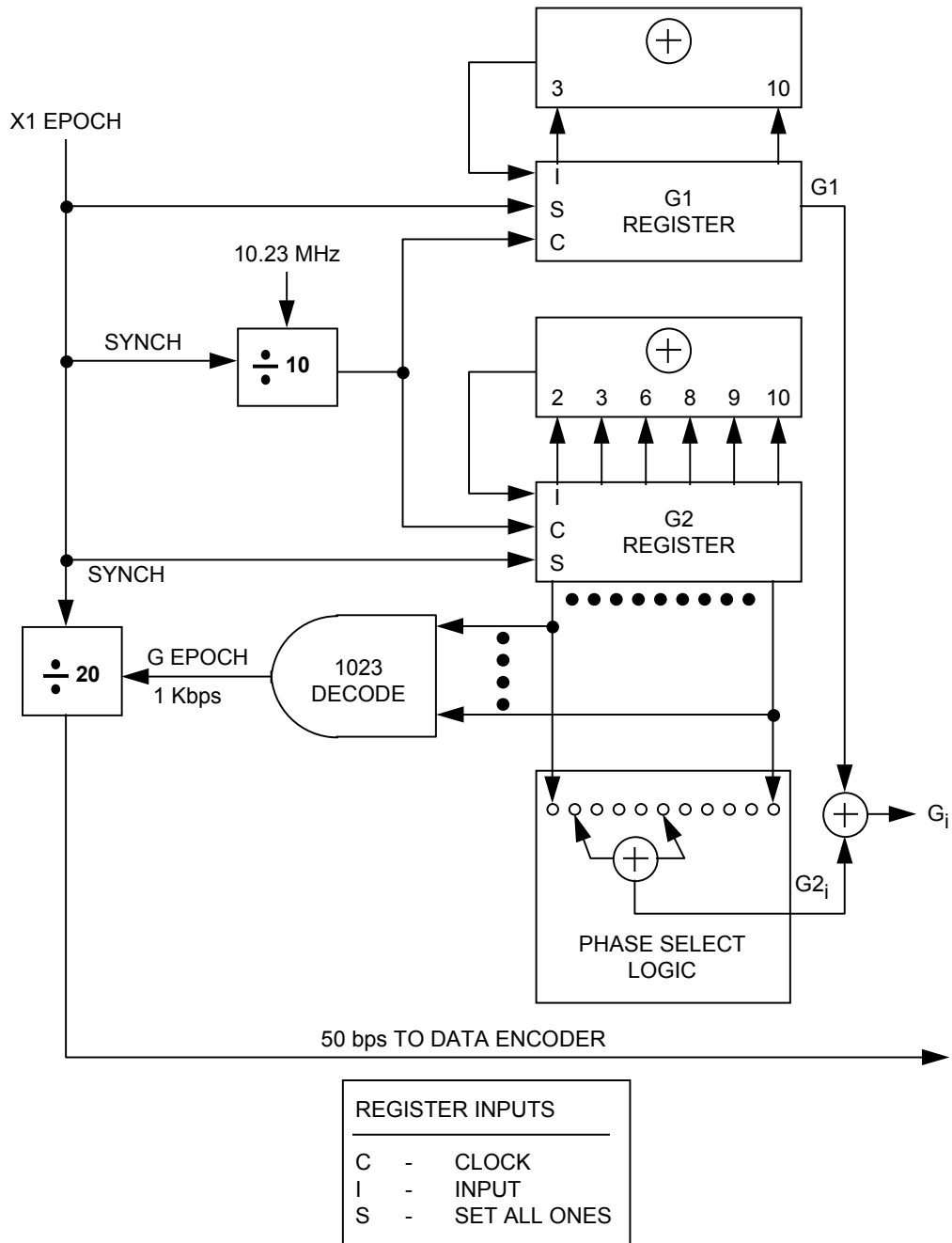

Figure 3-11. C/A-Code Generation

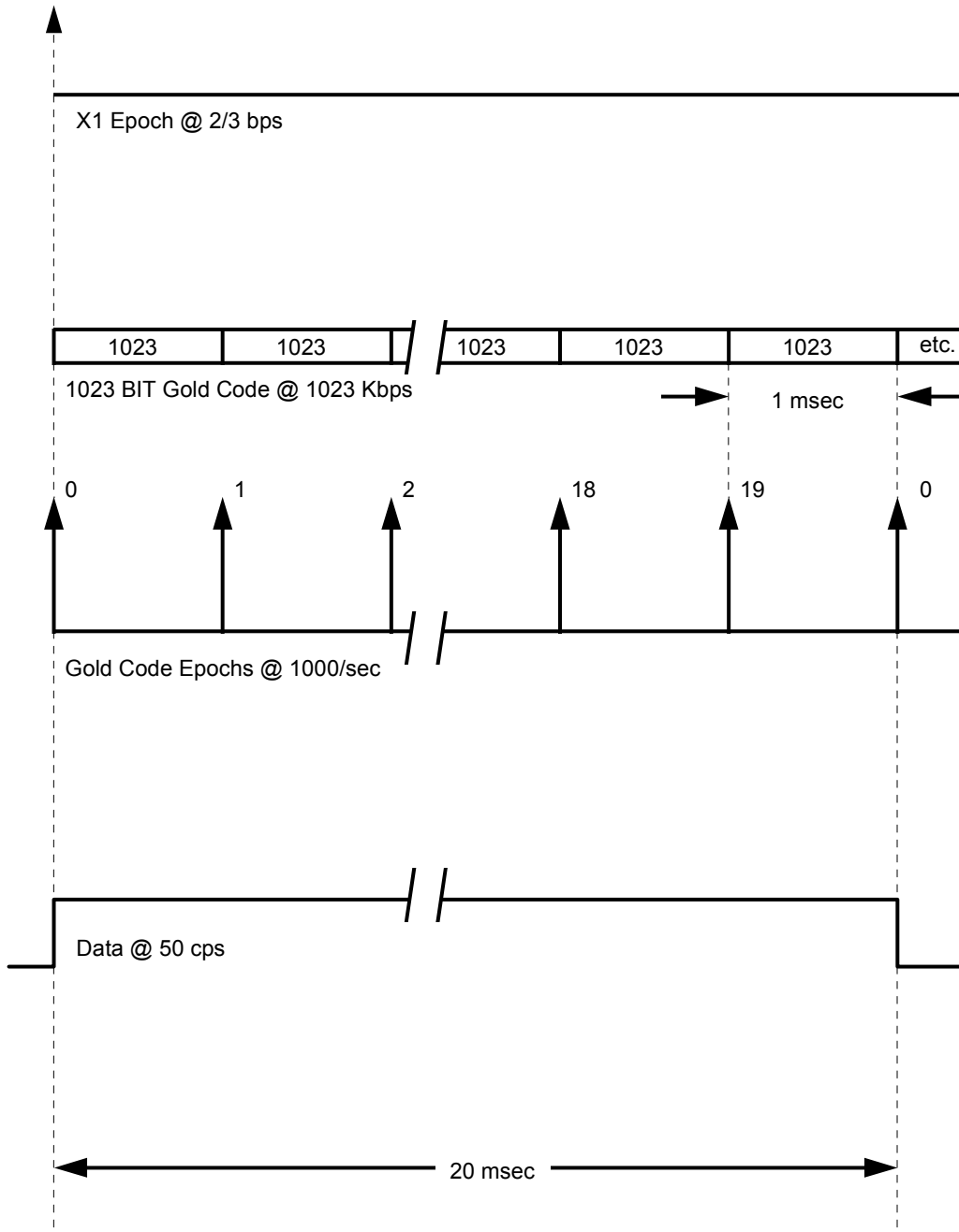

Figure 3-12. C/A-Code Timing Relationships

3.3.2.4 L2 CM-/L2 CL-Code Generation. Each $C_{M,i}(t)$ pattern (L2 CM-code) and $C_{L,i}(t)$ pattern (L2 CL-code) are generated using the same code generator polynomial each clocked at 511.5 Kbps. Each pattern is initiated and reset with a specified initial state (defined in Table 3-IA). $C_{M,i}(t)$ pattern is reset after 10230 chips resulting in a code period of 20 milliseconds, and $C_{L,i}(t)$ pattern is reset after 767250 chips resulting in a code period of 1.5 seconds. The L2 CM and L2 CL shift registers are initialized at the P-coder X1 epoch. The first L2 CM-code chip starts synchronously with the end/start of week epoch. Timing relationships related to the L2 CM-/L2 CL-codes are shown in Figure 3-12A.

The maximal polynomial used for L2 CM- and L2 CL-codes is 1112225171 (octal) of degree 27. The L2 CM and L2 CL code generator is conceptually described in Figure 3-12B using modular-type shift register generator.

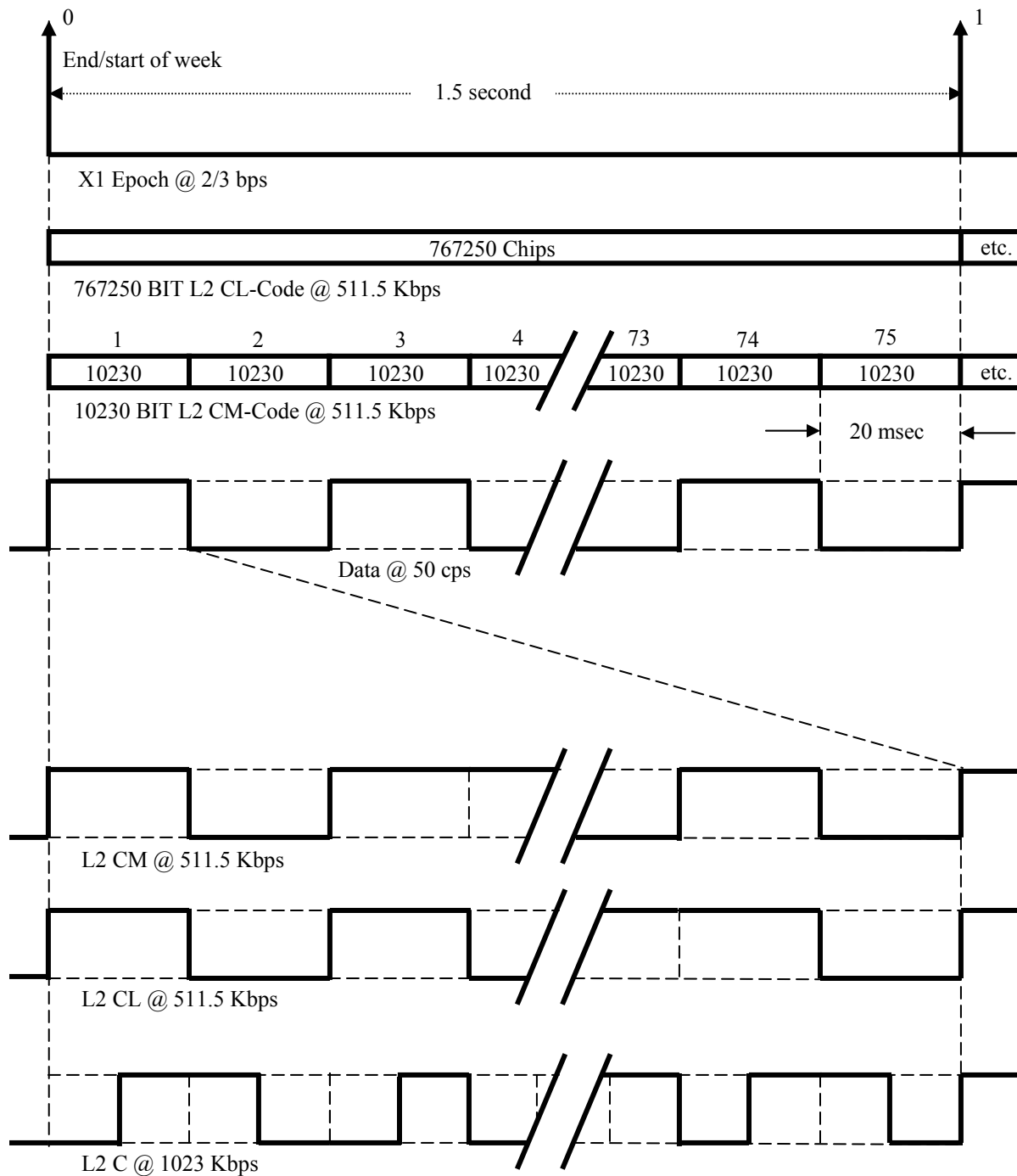

Figure 3-12A. L2 CM-/L2 CL-Code Timing Relationships

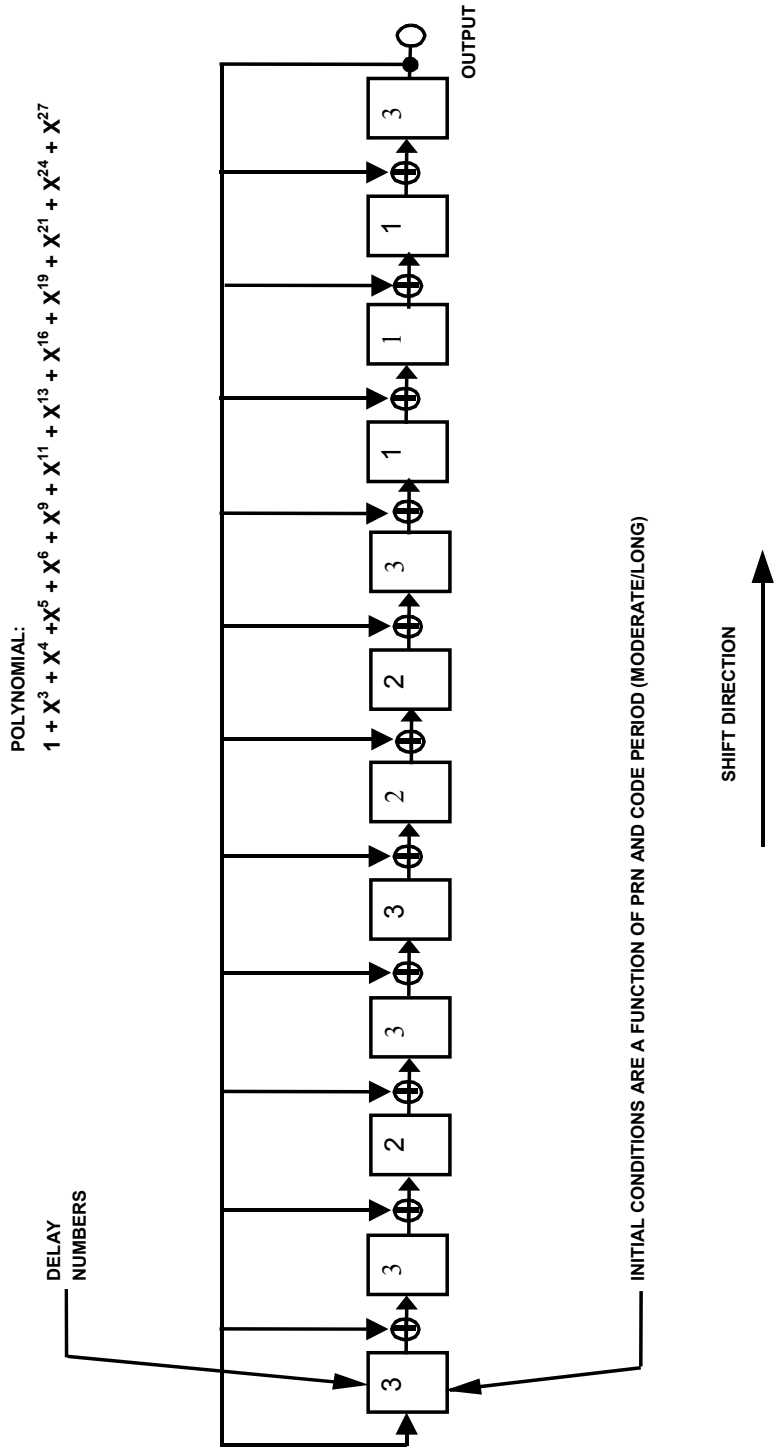

Figure 3-12B. L2 CM/L2 CL Shift Register Generator Configuration

UNCLASSIFIED

(This page intentionally left blank.)

**IRN-200C-005R1
ICD-GPS-200C
14 Jan 2003**

32d

UNCLASSIFIED

3.3.3 Navigation Data. The content and format of the NAV data, $D(t)$, and the L2 CNAV data, $D_C(t)$, are given in Appendices II and III, respectively, of this document.

3.3.3.1 Navigation Data Modulation. For Block IIF, the L2 CNAV bit train, $D_C(t)$, is rate $\frac{1}{2}$ encoded and, thus, clocked at 50 sps. The resultant symbol sequence is then Modulo-2 added to the L2 CM-code. For Block IIR-M, upon ground command, the NAV bit train, $D(t)$, can be rate $\frac{1}{2}$ encoded and be used to modulate the L2 CM-code. However, the data rate of $D(t)$ for this purpose will be 25 bps resulting in 50 sps.

3.3.3.1.1 Forward Error Correction. The L2 CNAV bit train, $D_C(t)$, will always be Forward Error Correction (FEC) encoded by a rate $\frac{1}{2}$ convolutional code. For Block IIR-M, the NAV bit train, $D(t)$, can be selected to be convolutionally encoded. The resulting symbol rate is 50 sps. The convolutional coding will be constraint length 7, with a convolutional encoder logic arrangement as illustrated in Figure 3-12C. The G1 symbol is selected on the output as the first half of a 40-millisecond data bit period.

Twelve-second navigation messages broadcast by the SV are synchronized with every eighth of the SV's P(Y)-code X1 epochs. However, the navigation message is FEC encoded in a continuous process independent of message boundaries (i.e. at the beginning of each new message, the encoder registers illustrated in Figure 3-12C contains the last six bits of the previous message).

Because the FEC encoding convolves successive messages, it is necessary to define which transmitted symbol is synchronized to SV time, as follows. The beginning of the first symbol that contains any information about the first bit of a message will be synchronized to every eighth X1 epoch (referenced to end/start of week). The users' convolutional decoders will introduce a fixed delay that depends on their respective algorithms (usually 5 constraint lengths, or 35 bits), for which they must compensate to determine system time from the received signal. This convolutional decoding delay and the various relationships with the start of the data block transmission and SV time are illustrated in Figure 3-12D.

3.3.4 GPS Time and SV Z-Count. GPS time is established by the Control Segment and is referenced to a UTC (as maintained by the U.S. Naval Observatory) zero time-point defined as midnight on the night of January 5, 1980/morning of January 6, 1980. The largest unit used in stating GPS time is one week defined as 604,800 seconds. GPS time may differ from UTC because GPS time shall be a continuous time scale, while UTC is corrected periodically with an integer number of leap seconds. There also is an inherent but bounded drift rate between the UTC and GPS time scales. The OCS shall control the GPS time scale to be within one microsecond of UTC (Modulo one second).

UNCLASSIFIED

The NAV data contains the requisite data for relating GPS time to UTC. The accuracy of this data during the transmission interval shall be such that it shall relate GPS time (maintained by the MCS of the CS) to UTC (USNO) within 90 nanoseconds (one sigma). This data is generated by the CS; therefore, the accuracy of this relationship may degrade if for some reason the CS is unable to upload data to a SV. At this point, it is assumed that alternate sources of UTC are no longer available, and the relative accuracy of the GPS/UTC relationship will be sufficient for users. Range error components (e.g. SV clock and position) contribute to the GPS time transfer error, and under normal operating circumstances (two frequency time transfers from SV(s) whose navigation message indicates a URA of eight meters or less), this corresponds to a 97 nanosecond (one sigma) apparent uncertainty at the SV. Propagation delay errors and receiver equipment biases unique to the user add to this time transfer uncertainty.

In each SV the X1 epochs of the P-code offer a convenient unit for precisely counting and communicating time. Time stated in this manner is referred to as Z-count, which is given as a 29-bit binary number consisting of two parts as follows:

- a. The binary number represented by the 19 least significant bits of the Z-count is referred to as the time of week (TOW) count and is defined as being equal to the number of X1 epochs that have occurred since the transition from the previous week. The count is short-cycled such that the range of the TOW-count is from 0 to 403,199 X1 epochs (equaling one week) and is reset to zero at the end of each week. The TOW-count's zero state is defined as that X1 epoch which is coincident with the start of the present week. This epoch occurs at (approximately) midnight Saturday night-Sunday morning, where midnight is defined as 0000 hours on the Universal Coordinated Time (UTC) scale which is nominally referenced to the Greenwich Meridian. Over the years the occurrence of the "zero state epoch" may differ by a few seconds from 0000 hours on the UTC scale since UTC is periodically corrected with leap seconds while the TOW-count is continuous without such correction. To aid rapid ground lock-on to the P-code signal, a truncated version of the TOW-count, consisting of its 17 most significant bits, is contained in the hand-over word (HOW) of the L-Band downlink data stream; the relationship between the actual TOW-count and its truncated HOW version is illustrated by Figure 3-13.
- b. The ten most significant bits of the Z-count are a Modulo 1024 binary representation of the sequential number assigned to the current GPS week (see paragraph 6.2.4). The range of this count is from 0 to 1023 with its zero state being defined as the GPS week number zero and every integer multiple of 1024 weeks, thereafter (i.e. 0, 1024, 2048, etc.).

**IRN-200C-005R1
ICD-GPS-200C
14 Jan 2003**

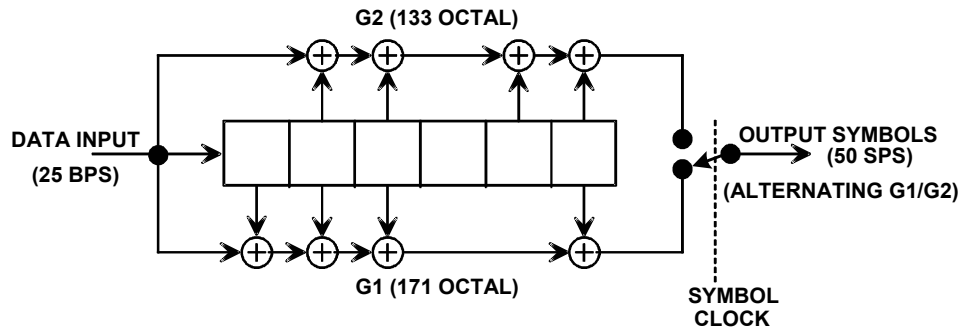

Figure 3-12C. Convolutional Encoder

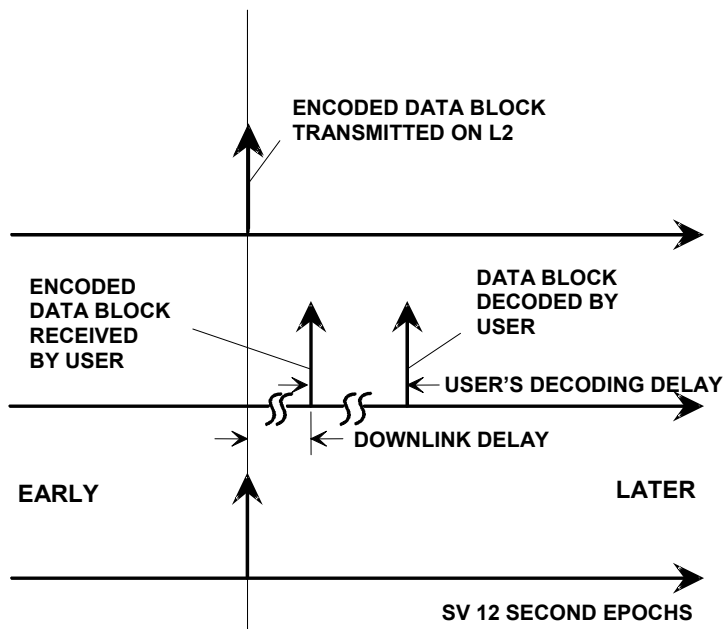

Figure 3-12D. Convolutional Transmit/Decoding Timing Relationships

UNCLASSIFIED

(This page intentionally left blank.)

**IRN-200C-005R1
ICD-GPS-200C
14 Jan 2003**

UNCLASSIFIED

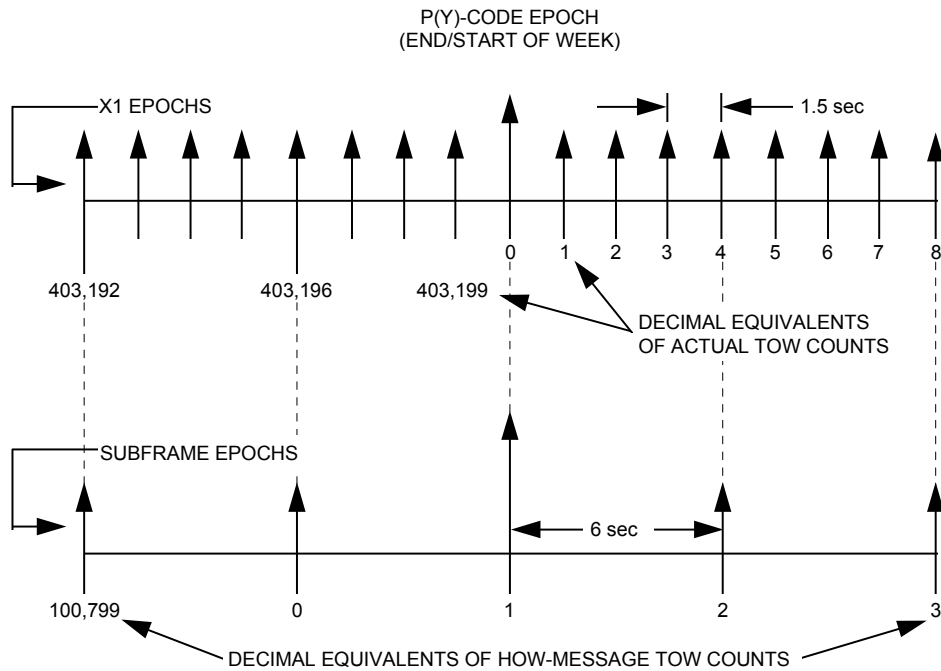

NOTES:

1. TO AID IN RAPID GROUND LOCK-ON THE HAND-OVER WORD (HOW) OF EACH SUBFRAME CONTAINS A TRUNCATED TIME-OF-WEEK (TOW) COUNT
2. THE HOW IS THE SECOND WORD IN EACH SUBFRAME (REFERENCE PARAGRAPH 20.3.3.2).
3. THE HOW-MESSAGE TOW COUNT CONSISTS OF THE 17 MSBs OF THE ACTUAL TOW COUNT AT THE START OF THE NEXT SUBFRAME.
4. TO CONVERT FROM THE HOW-MESSAGE TOW COUNT TO THE ACTUAL TOW COUNT AT THE START OF THE NEXT SUBFRAME, MULTIPLY BY FOUR.
5. THE FIRST SUBFRAME STARTS SYNCHRONOUSLY WITH THE END/START OF WEEK EPOCH.

Figure 3-13. Time Line Relationship of HOW Message

UNCLASSIFIED

(This page intentionally left blank.)

**ICD-GPS-200C
10 OCT 1993**

UNCLASSIFIED

4. NOT APPLICABLE

(This page intentionally left blank.)

5. NOT APPLICABLE

(This page intentionally left blank.)

6. NOTES

6.1 Acronyms

AI	-	Availability Indicator
AODO	-	Age of Data Offset
A-S	-	Anti-Spoofing
Autonav	-	Autonomous Navigation
BPSK	-	Bi-Phase Shift Key
cps	-	cycles per second
CRC	-	Cyclic Redundancy Check
CS	-	Control Segment
DN	-	Day Number
EAROM	-	Electrically Alterable Read-Only Memory
ECEF	-	Earth-Centered, Earth-Fixed
ECI	-	Earth-Centered, Inertial
EOE	-	Edge-of-Earth
EOL	-	End of Life
ERD	-	Estimated Range Deviation
FEC	-	Forward Error Correction
GPS	-	Global Positioning System
HOW	-	Hand-Over Word
ICC	-	Interface Control Contractor
ICD	-	Interface Control Document
ID	-	Identification
IODC	-	Issue of Data, Clock
IODE	-	Issue of Data, Ephemeris
ISC	-	Inter-Signal Correction
LSB	-	Least Significant Bit
LSF	-	Leap Seconds Future
L2 C	-	L2 Civil Signal
L2 CL	-	L2 Civil-Long Code
L2 CM	-	L2 Civil-Moderate Code
L2 CNAV	-	L2 C Navigation
MCS	-	Master Control Station
MSB	-	Most Significant Bit

UNCLASSIFIED

NAV	-	Navigation
NDUS	-	Nudet Detection User Segment
NMCT	-	Navigation Message Correction Table
NSC	-	Non-Standard C/A-Code
NSCL	-	Non-Standard L2 CL-Code
NSCM	-	Non-Standard L2 CM-Code
NSY	-	Non-Standard Y-code
OBCP	-	On-Board Computer Program
OCS	-	Operational Control Segment
PRN	-	Pseudo-Random Noise
RF	-	Radio Frequency
RMS	-	Root Mean Square
SA	-	Selective Availability
SEP	-	Spherical Error Probable
sps	-	symbols per second
SS	-	Space Segment
SV	-	Space Vehicle
SVN	-	Space Vehicle Number
TBD	-	To Be Determined
TBS	-	To Be Supplied
TLM	-	Telemetry
TOW	-	Time Of Week
UE	-	User Equipment
URA	-	User Range Accuracy
URE	-	User Range Error
US	-	User Segment
USNO	-	U.S. Naval Observatory
UTC	-	Coordinated Universal Time
WGS 84	-	World Geodetic System 1984
WN	-	Week Number
WN _e	-	Extended Week Number

IRN-200C-005R1
ICD-GPS-200C
14 Jan 2003

6.2 Definitions

6.2.1 User Range Accuracy. User range accuracy (URA) is a statistical indicator of the ranging accuracies obtainable with a specific SV. URA is a one-sigma estimate of the user range errors in the navigation data for the transmitting satellite. It includes all errors for which the Space and Control Segments are responsible. It does not include any errors introduced in the user set or the transmission media. While the URA may vary over a given subframe fit interval, the URA index (N) reported in the NAV message corresponds to the maximum value of URA anticipated over the fit interval.

6.2.2 SV Block Definitions. The following block definitions are given to facilitate discussion regarding the capability of the various blocks of GPS satellites to support the SV-to-US interface.

6.2.2.1 Developmental SVs. The original concept validation satellites developed by Rockwell International and designated as satellite vehicle numbers (SVNs) 1-11 are termed "Block I" SVs. These SVs were designed to provide 3-4 days of positioning service without contact from the CS. These SVs transmitted a configuration code of 000 (reference paragraph 20.3.3.5.1.6). There are no longer any active Block I SVs in the GPS constellation. The last Block I SV was decommissioned in 1995.

6.2.2.2 Operational SVs. The operational satellites are designated Block II, Block IIA, Block IIR, Block IIR-M and Block IIF SVs. Characteristics of these SVs are provided below. Modes of operation for these SVs and accuracy of positioning services provided are described in paragraphs 6.3.2 through 6.3.4. These SVs transmit configuration codes as specified in paragraph 20.3.3.5.1.6. The navigation signal provides no direct indication of the type of the transmitting SV.

6.2.2.2.1 Block II SVs. The first block of full scale operational SVs developed by Rockwell International are designated as SVNs 13-21 and are termed "Block II" SVs. These SVs were designed to provide 14 days of positioning service without contact from the CS.

6.2.2.2.2 Block IIA SVs. The second block of full scale operational SVs developed by Rockwell International are designated as SVNs 22-40 and are termed "Block IIA" SVs. These SVs were designed to provide 180 days of positioning service without contact from the CS.

6.2.2.2.3 Block IIR SVs. The block of operational replenishment SVs developed by Martin Marietta are designated as SVNs 41-61 and are termed "Block IIR" SVs. These SVs will provide at least 14 days of positioning service without contact from the CS when the SVs are operating in the Block IIA mode and will provide a minimum of 180 days of positioning service without contact from the CS when operating in autonomous navigation (Autonav) mode.

6.2.2.2.4 Block IIR-M SVs. The subset of operational replenishment SVs developed by Lockheed Martin which are "Modernized" configuration of "Block IIR" SVs are termed "Block IIR-M".

6.2.2.2.5 Block IIF SVs. The block of operational replenishment SVs developed by Boeing are designated as SVNs 62-73 and are termed "Block IIF" SVs. This is the first block of operational SVs that transmit the L5 Civil signal.

6.2.3 Operational Interval Definitions. The following three operational intervals have been defined. These labels will be used to refer to differences in the interface definition as time progresses from SV acceptance of the last navigation data upload.

6.2.3.1 Normal Operations. The SV is undergoing normal operations whenever the fit interval flag (reference paragraph 20.3.3.4.3.1) is zero.

6.2.3.2 Short-term Extended Operations. The SV is undergoing short-term extended operations whenever the fit interval flag is one and the IODE (reference paragraph 20.3.4.4) is less than 240.

6.2.3.3 Long-term Extended Operations. The SV is undergoing long-term extended operations whenever the fit interval flag is one and the IODE is in the range 240-255.

6.2.4 GPS Week Number. The GPS week numbering system is established with week number zero (0) being defined as that week which started with the X1 epoch occurring at midnight UTC(USNO) on the night of January 5, 1980/ morning of January 6, 1980. The GPS week number continuously increments by one (1) at each end/start of week epoch without ever resetting to zero. Users must recognize that the week number information contained in the Nav Message may not necessarily reflect the current full GPS week number (see paragraphs 20.3.3.3.1.1, 20.3.3.5.1.7, 20.3.3.5.2.4, and 30.3.3.1.1.1).

6.2.5 Calendar Year. The calendar year used for the calendar year counter (see paragraph 20.3.3.5.1.13) is the year number from the Gregorian Calendar.

6.2.6 GPS Day. The GPS day used for the calendar year counter (see paragraph 20.3.3.5.1.13) is 57600 X1 epochs in duration. The start of the GPS day is the start of the UTC(USNO) day minus the UTC(USNO)-GPS correction for that particular UTC(USNO) day.

6.2.7 L5 Civil Signal. L5 is the GPS downlink signal at a nominal carrier frequency of 1176.45 MHz. The L5 signal is only available on Block IIF and subsequent blocks of SVs and the signal is specified/described in a separate and different interface control document.

6.3 Supporting Material

6.3.1 Received Signals. The guaranteed minimum user-received signal levels are defined in paragraph 3.3.1.6. As additional supporting material, Figure 6-1 illustrates an example variation in the minimum received power of the near-ground user-received L1 and L2 signals from Block II/I/A/IIR SVs as a function of SV elevation angle.

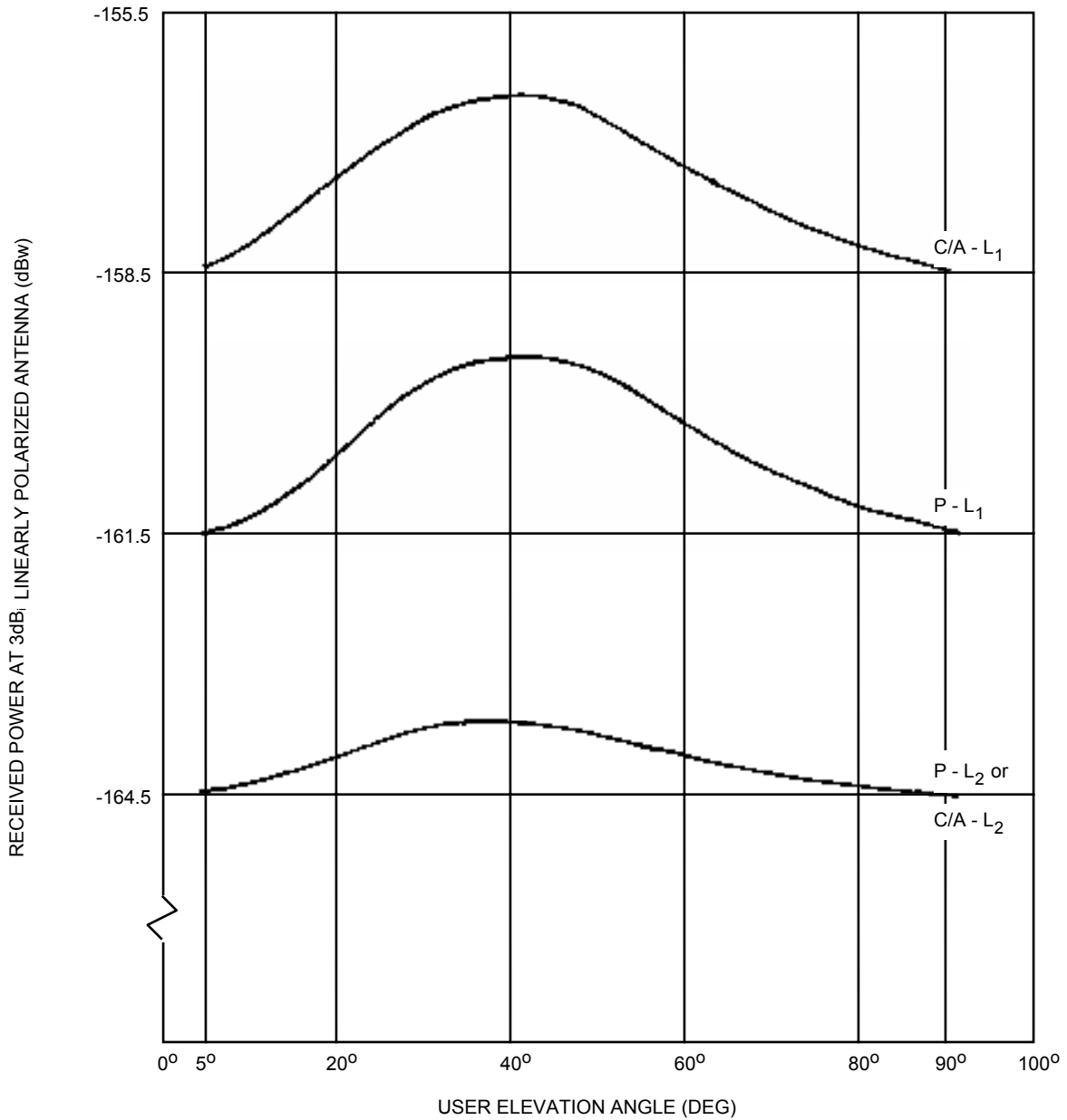

Figure 6-1. User Received Minimum Signal Level Variations (Example, Block II/IIA/IIR)

Higher received signals levels can be caused by such factors as SV attitude errors, mechanical antenna alignment errors, transmitter power output variations due to temperature variations, voltage variations and power amplifier variations, and due to a variability in link atmospheric path loss. For Block II/IIA and IIR SVs, the maximum received signal levels as a result of these factors is not expected to exceed -155.5 dBW and -153.0 dBW, respectively, for the P(Y) and C/A components of the L1 channel, nor -158.0 dBW for either signal on the L2 channel. For Block IIR-M and IIF SVs, the maximum received signal levels as a result of these factors is not expected to exceed -155.5 dBW and -153.0 dBW, respectively, for the P(Y) and C/A components of the L1 channel and L2 channel. In addition, due to programmable power output capabilities of Block IIR-M and IIF SVs, under certain operational scenarios, individual signal components of Block IIR-M/IIF SVs may exceed the previously stated maximum but are not expected to exceed -150 dBW.

6.3.2 Extended Navigation Mode (Block II/IIA). The Block II and IIA SVs are capable of being uploaded by the CS with 182 days of navigation data to support a 180 day positioning service. Due to memory retention limitations, the Block II SVs may not transmit correct data for the entire 180 days but are guaranteed to transmit correct data for at least 14 days to support short-term extended operations. Under normal conditions the CS will provide daily uploads to each SV, which will allow the SV to maintain normal operations as defined in paragraph 6.2.3.1 and described within this ICD. During normal operations, the SVs will have a user range error that is at or below a level required to support a positioning accuracy of 16 meters spherical error probable (SEP). In addition, the almanac data, UTC parameters and ionospheric data will be maintained current to meet the accuracy specified in this ICD.

If the CS is unable to upload the SVs (the CS is unavailable or the SV is unable to accept and process the upload), each SV will individually transition to short-term extended operations and eventually to long-term extended operations (based on time from each SV's last upload) as defined in paragraphs 6.2.3.2 and 6.2.3.3, and as further described throughout this ICD. As time from upload continues through these three operational intervals, the user range error of the SV will increase, causing a positioning service accuracy degradation. The rate of accuracy degradation is slow over the short-term extended operations interval, such that at the end of this interval (approximately 14 days after upload) the US will be able to achieve a positioning accuracy of 425 meters SEP. The rate of accuracy degradation increases in the long-term extended interval, such that by the 180th day after the last upload, the positioning errors will have grown to 10 kilometers SEP. During these intervals the URA will continue to provide the proper estimate of the user range errors.

During short-term and long-term extended operations (approximately day 2 through day 182 after an upload), the almanac data, UTC parameters and ionospheric data will not be maintained current and will degrade in accuracy from the time of last upload.

IRN-200C-005R1
ICD-GPS-200C
14 Jan 2003

6.3.3 Block IIA Mode (Block IIR/IIR-M). The Block IIR/IIR-M SVs, when operating in the Block IIA mode, will perform similarly to the Block IIA SVs and will provide at least 14 days of positioning service (through short-term extended operations) without contact from the CS.

6.3.4 Autonomous Navigation Mode. The Block IIR/IIR-M and Block IIF SV, in conjunction with a sufficient number of other Block IIR/IIR-M or Block IIF SVs, operates in an Autonav mode when commanded by the CS. Each Block IIR/IIR-M/IIF SV in the constellation determines its own ephemeris and clock correction parameters via SV-to-SV ranging, communication of data, and on-board data processing which updates data uploaded by the CS. In the Autonav mode the Block IIR/IIR-M/IIF SV will maintain normal operations as defined in paragraph 6.2.3.1 and as further described within this ICD, and will have a user range error that is at or below a level required to support 16 meter SEP accuracy for Block IIR/IIR-M. If the CS is unable to upload the SVs, the Block IIR/IIR-M SVs will maintain normal operations for period of at least 180 days after the last upload and the Block IIF SVs will maintain normal operations for period of at least 60 days.

In the Autonav mode, the almanac data, UTC parameters and ionospheric data are still calculated and maintained current by the CS and uploaded to the SV as required. If the CS is unable to upload the SVs, the almanac data, UTC parameters and ionospheric data will not be maintained current and will degrade in accuracy from the time of the last upload.

10. APPENDIX I. LETTERS OF EXCEPTION

10.1 Scope. As indicated in paragraph 1.3, initial signature approval of this document, as well as approval of subsequent changes to the document, can be contingent upon a "letter of exception". This appendix depicts such "letters of exception" when utilized by any signatory of this document in the initial approval cycle and/or in the change approval process. The ICC will omit such letters of exception from subsequent revisions of this document based on written authorization by the respective signatory (without processing a proposed interface revision notice (PIRN) for approval). When some (but not all) of the exceptions taken by a signatory are resolved, the signatory shall provide the ICC with an updated letter of exception for inclusion in the next ICD revision (without processing a PIRN for approval).

10.2 Applicable Documents. The documents listed in Section 2.0 shall be applicable to this appendix.

10.3 Letters of Exception. If signature approval of this document -- as affixed to the cover page -- is marked by an asterisk, it indicates that the approval is contingent upon the exceptions taken by that signatory in a letter of exception. Any letter of exception which is in force for the revision of the ICD is depicted in Figure 10-1. Signatories for whom no letter of exception is shown have approved this version of the document without exception.

(This page intentionally left blank.)

UNCLASSIFIED

Space Systems Division
Rockwell International Corporation
2600 Westminster Boulevard
P.O. Box 3644
Seal Beach, California 90740-7644



In reply refer to 93MA3728

Date: September 22, 1993
To: The ARINC Companies
11770 E. Warner Ave., Suite 210
Fountain Valley, CA 92708
Subject: Rockwell International Letter of Exception to
ICD GPS-200 PIRN-200A-006NC, dated November
21,1986.
Attention: Thomas R. Denigan
Reference: ARINC Companies FAX dated September 20, 1993,
T. R. Denigan to D. L. Butler, same subject.

It is Rockwell's position that the statement requested in the subject letter of exception be incorporated, as written, in the next revision to ICD-200. The 'B' revision of ICD-200 incorporated only the last portion of the requested change "...the initialization vector for X2A is 100100100101 and for X2B is 010101010100." It is felt that the first portion of the sentence, "Using the same convention identified for X1A and X1B,..." will aid the reader of the ICD in understanding the derivation of the X2A and X2B terms.

ROCKWELL INTERNATIONAL	
Space Systems Division	
Signature on file	Signature on file
W. L. Young, Manager	F. E. Cooper, Chief
Engineer	
Contracts & Proposals	GPS Program

cc: D. L. Butler
W. F. Fratzke

Figure 10-1. Letter of Exception (sheet 1 of 15)

**IRN-200C-002
ICD-GPS-200C
25 SEP 1997**

UNCLASSIFIED

Collins Avionics & Communications Division
Rockwell International Corporation
350 Collins Road NE
Cedar Rapids, IA 52498
(319) 395-1000



September 23, 1993

ARINC Research Corporation
11770 Warner Avenue, Suite 210
Fountain Valley, CA 92708

Attention: Mr. Tom Denigan

Subject: Review of ICD-GPS-200B Outstanding Letters of Exception in
Preparation of ICD-GPS-200C

Dear Mr. Denigan:

A review of Rockwell International's Collins Avionics & Communications Division, outstanding Letters of Exception as listed in IRN-200B-007 to ICD-GPS-200B shows 2 Letters of Exception that have been satisfied or are no longer pertinent:

sheet 46, (letter dated March 31, 1987)
sheet 53 & 54, (letter dated September 10, 1986)

The following letters as listed in IRN-200B-007 to ICD-GPS-200B are still pertinent and are to be included in any revised ICD-GPS-200 releases:

sheet 54a, 54c (letter dated March 27, 1991)
sheet 56g (letter dated September 23, 1992)

Sincerely,

Signature on file
C.S. Olson
Program Manager

Figure 10-1. Letter of Exception (sheet 2 of 15)

**IRN-200C-002
ICD-GPS-200C
25 SEP 1997**

UNCLASSIFIED

Collins Avionics & Communications Division
Rockwell International Corporation
350 Collins Road NE
Cedar Rapids, IA 52498
(319) 395-1000



2458b/0048b

March 27, 1991

ARINC Research Corporation
4410 East Fountain Blvd., Suite 100
Colorado Springs, CO 80916

Attention: Ms. Cheryl Abendschan

Subject: Rockwell CACD Letter of Exception against PIRN-200B-001B (as corrected by ARINC memo on typos and oversights, 19 MAR 91)

The subject PIRN-200B-001B documents the extended navigation capabilities inherent in the Space Segment/User Segment interface as a result of the incorporation of mission package software release OR5.10 into the Control Segment. CACD's approval of this PIRN, which indicates concurrence that the PIRN accurately reflects the as-built Control and Space Segments in the area of extended navigation, is given with exception.

CACD takes exception because:

1. The extended navigation capabilities documented by the PIRN are not a requirement of the GPS Phase III User Equipment (UE) contract F04701-85-C-0038, the GPS UE Phase IV contract F04701-90-C-0092, or the GPS MAGR Contract F04701-91-C-0003. Therefore, the GPS User Equipment, which has been and will be developed under these contracts, do no operate in compliance with extended navigation.
2. While we may technically comment on the impact to the UE as a result of OR5.10 implementation, we cannot (as PIRN approval might otherwise indicate) verify that OR5.10 implements the extended navigation requirements identified in the PIRN.

In summary, "Long Term Extended" operations from 15 to 180 days following an upload from the Control Segment are not supported by the Phase III GPS UE. Attachment 1 contains the detailed comments on the PIRN items to which CACD takes exception.

Sincerely,

Signature on file
J. L. Arnold
GPS Programs Manager

Enclosure
cc: Lt. Jim Dagley
Capt. Greg Laushine

Figure 10-1. Letter of Exception (sheet 3 of 15)

**IRN-200C-002
ICD-GPS-200C
25 SEP 1997**

UNCLASSIFIED

ATTACHMENT 1

Rockwell CACD Exceptions to PIRN-200B-001B

PIRN ITEM	Rockwell CACD Comment
17, 18	<p>These PIRN items document the change in the definition of the Week Number in subframe 1, word 3 due to the implementation of long term extended ephemeris curve fits which cross GPS week boundaries. The new definition states that the week number is the ten most significant bits of the Z-count and will represent the GPS week of the <u>start</u> of the data set transmission interval. Previously, the week number always represented the <u>current</u> GPS week of transmission. CACD takes exception to this redefinition because:</p> <ol style="list-style-type: none"> 1. The PIRN introduces an inconsistency with the definition of Z-count given in paragraph 3.3.4, page 33 which states that “the ten most significant bits of the Z-count are a binary representation of the sequential number assigned to the <u>present</u> GPS week (Module 1024).” 2. Since the GPS week being transmitted by the Space Segment could vary from SV to SV (depending upon time of upload) and since the transmitted GPS week could be different from the current GPS week by one week starting on day 29 after an upload, the GPS UE could navigate using the wrong GPS week. Use of the wrong GPS week could cause navigation interruptions and could result in the incorrect time-tagging of the satellite data. The user could therefore be provided with navigation data which is marked valid when, in fact, it is not valid. This is an unacceptable situation.
22,29,31, 57a, 57b,58, 60	<p>These PIRN items document the change in the definition of the ephemeris fit interval flag for a value equal to 1 and its corresponding relationship to the IODC/IODE during extended operations. The GPS UE supports only a fit interval of 6 hours when the fit interval flag equals 1. The newly defined ephemeris fit intervals of 8, 14, 26, 50, 74, 98, 122, and 146 hours for Long Term Extended Operations are not supported and the UE will compute 6 hour curve fits whenever these are in effect.</p>

Figure 10-1. Letters of Exception (sheet 4 of 15)

**IRN-200C-002
ICD-GPS-200C
25 SEP 1997**

UNCLASSIFIED

ATTACHMENT 1 (cont.)

Rockwell CACD Exceptions to PIRN-200B-001B

PIRN ITEM	Rockwell CACD Comment
39, 40, 50, 54	<p>These PIRN items describe the almanac data sets and how the almanac URE grows throughout extended operations. The GPS UE requirements for almanac-based direct P-code TTFF (time to first fix) are only applicable to Normal Operations in which the almanac parameters have been updated within the last six days. Extended operations <u>may</u> jeopardize missions of those users who require efficient almanac-based direct P-code TTFFs.</p>
43	<p>This PIRN item documents the fact that the health summary in subframe 5, page 25 is only updated at the time of almanac upload. During extended operations the health summary may become outdated due to the length of time since the last upload.</p> <p>If the health summary becomes outdated and does not accurately reflect the status of the GPS constellation, the TTFF for the GPS UE may be delayed. This is due to the time wasted on the possible acquisition of unhealthy SVs which were marked “healthy” by the health summary. Also, attempts to acquire healthy SVs which are marked unhealthy will not be made. As a result, extended operations <u>may</u> jeopardize missions of those users who require efficient TTFF.</p>
45,46	<p>These PIRN items document the changes for the UTC parameter data sets during extended operations. The GPS UE uses the UTC parameters to provide the user with precise time. Exception is taken because:</p> <ol style="list-style-type: none"> 1. CACD is not confident that the accuracy of the UTC parameters can be maintained throughout extended operations. This accuracy is specified as 90 ns (one sigma) on ICD-GPS-200B page 32. As a result, extended operations <u>may</u> jeopardize missions of those users who require precise UTC. 2. Since the GPS UE does not account for the degraded accuracy of the UTC parameters as a function of time during extended operations, the user may be provided with an incorrect estimate of his time accuracy which again <u>may</u> jeopardize his mission. CACD believes the UTC parameters’ accuracy, as a function of time, should be specified in some GPS system specification.

Figure 10-1. Letters of Exception (sheet 5 of 15)

**IRN-200C-002
ICD-GPS-200C
25 SEP 1997**

UNCLASSIFIED

Collins Avionics & Communications Division
Rockwell International Corporation
350 Collins Road NE
Cedar Rapids, IA 52498
(319) 395-1000



September 23, 1992

ARINC Research Corporation
11770 Warner Avenue, Suite 210
Fountain Valley, CA 92708

Attention: Mr. Peter Fyfe

Subject: PIRN-200B-009A Rockwell CACD Letter of Exception

Dear Mr. Fyfe:

The subject PIRN-200B-009A which documents the changes to the Space Segment/User Segment interface for the Block IIR SVs is hereby approved by Rockwell CACD with the following exception:

The PIRN states that UTC parameters (PIRN items 4, 20), ionospheric model parameters (PIRN items 21, 27a), and almanac data (PIRN items 22a, 22b) will degrade when the Block IIR SVs do not receive an upload from the Control Segment. Since the IIR SVs indicate "normal operations" (curve fit interval flag of 4 hours) at all times, dome user segment requirements cannot be met during "normal operations" in the absence of Control Segment uploads. These affected requirements are precise UTC time transfer and almanac-based direct P-code time to first fix.

The affected User Equipment (UE) is that designed and developed by Rockwell CACD under the GPS UE Phase III Contract F04701-85-C-0038, GPS UE Phase IV Contract F04701-90-C-0092, and GPS MAGR Contract F04701-91-C-0003.

Sincerely,

Signature on file
C. S. Olson
Program Manager

CSS/jk

Figure 10-1. Letters of Exception (sheet 6 of 15)

**IRN-200C-002
ICD-GPS-200C
25 SEP 1997**

Collins Avionics & Communications Division
Rockwell International Corporation
350 Collins Road NE
Cedar Rapids, IA 52498
(319) 395-1000



June 12, 1995

ARINC Research Corporation
2250 East Imperial Highway, Suite 450
El Segundo, CA 90245-3509

Attention: Mr. Thomas Denigan
Subject: PIRN-200C-001 Rockwell CACD Letter of Exception
Enclosure: Approval sheet for PIRN-300C-001
References: ARINC Research Corporation letter dated January 16, 1995;
Subject: PIRN-200C-001 to ICD-GPS-200C

The subject PIRN-200C-001 is approved by Rockwell CACD with the following exception:

The effect of Item 2, "Change Section 20.3.3.5.2.2, page 121" of this PIRN is that computed almanac age in Rockwell CACD government User Equipment (UE) will be approximately 14 hours older than actual almanac age. Since almanac age computation is for display/output purposes only there is no impact to receiver operation or navigation solution accuracy. CACD computes an almanac time-of-transmission that is nominally the multiple of 2^{12} seconds truncated from 3.5 days prior to the almanac reference time, t_{oa} . Item 2 of subject PIRN-200C-001 documents the change of t_{oa} from being nominally the multiple of 2^{12} seconds truncated from 3.5 days (84 hours) after the first valid transmission time for an almanac set to being nominally the multiple of 2^{12} seconds truncated from 70 hours after the first valid transmission time for an almanac set. Therefore, Rockwell CACD government UE will compute and output an incorrect almanac age by approximately 14 hours.

Figure 10-1. Letters of Exception (sheet 7 of 15)

IRN-200C-002
ICD-GPS-200C
25 SEP 1997

The second sentence of paragraph 20.3.3.5.2.2, “The almanac is updated often enough to ensure that GPS time, t , shall differ from t_{oa} by less than 3.5 days during the transmission period”, must not change. This is to ensure the proper resolution of the GPS week number associated with the almanac.

Technical questions concerning this matter should be referenced to Lawrence Burns at (319)395-2616.

Sincerely,

Signature on file
Craig Olson
GPS Program Manager

Figure 10-1. Letters of Exception (sheet 8 of 15)

**IRN-200C-002
ICD-GPS-200C
25 SEP 1997**



International Business Machines Corporation

800 N. Frederick Avenue
Gaithersburg, MD 20879

RD001001935
October 1, 1993

Mr. Tom Denigan
ARINC Research Corporation
11770 Warner Avenue, suite 210
Fountain Valley, CA 92780

Subject: IBM "Letter of Exception" against ICD-GPS-200B as
Modified by IRN-200B-001B

- Reference:
1. ICD-GPS-200B, dated November 30, 1987
 2. IRN-200B-001B, dated April 15., 1991
 3. IRN-200B-002, dated July 26, 1991
 4. IRN-200B-003, dated December 2, 1991
 5. IRN-200B-004, dated December 5, 1991
 6. IRN-200B-005, dated December 16, 1991
 7. IRN-200B-006, dated December 9, 1992
 8. IRN-200B-007, dated July 19, 1993
 9. IBM letter 020689-2, dated February 6, 1989
 10. Contract F04701-90-C-0009

Dear Mr. Denigan:

With the release of the referenced IRN-200B-001B through -007, this letter represents the current IBM letter of exception against ICD-GPS-200B, replacing Reference 9.

The IBM contract does not support the following:

Block I end of data transmission (Paragraph 20.3.2)

The option of repeated almanacs for 12 or fewer SVs (Paragraphs 20.3.3.5.1.2, 20.3.3.5.1.3)

The use of pages 2, 3, 4, 5, 7, 8, 9, and 10 of subframe 4 for purpose other than almanac data for SVs 25 through 32 (Paragraphs 20.3.3.5.1, 20.3.3.5.1.1, 20.3.3.5.1.3, Table 20-V)

Figure 10-1. Letters of Exception (sheet 9 of 15)

IRN-200C-002
ICD-GPS-200C
25 SEP 1997

UNCLASSIFIED

-2-

Mr. Tom Denigan

RD001001935
October 1, 1993

Questions and coordination related to the technical content of ICD-GPS-200 should be addressed to Ming Kang Chien at 301/240-6449.

Very truly yours,

Signature on file
Magdalena V. Clyne
Contract Administrator

cc: Capt. B. Schrimsher, SMC/CZGD 1
Lt. R. Layton, SMC/CZET 1

Figure 10-1. Letters of Exception (sheet 10 of 15)

**IRN-200C-002
ICD-GPS-200C
25 SEP 1997**

UNCLASSIFIED

MARTIN MARIETTA ASTRO SPACE

POST OFFICE BOX 8555
PHILADELPHIA, PENNSYLVANIA 19101

17 August 1994
GPS IIR-CM-1046

ARINC Research Corporation
2250 E. Imperial Highway, Suite 450
El Segundo, CA 90245-3509

Attention: Ms. Pat Alexander

Subject: Approval of ICD-GPS-200, Revision C

Reference: Contract F04701-89-C-0073
ICD-GPS-200, Revision C dated 10 October 1993

Dear Ms. Alexander:

Martin Marietta Astro Space approves with exception ICD-GPS-200, Revision C as evidenced by the attached signed approval sheet. The areas of exception are both general and specific in nature.

General Areas of Exceptions

Martin Marietta takes exception to specific changes in requirements originally conveyed in IRN Nos. IRN-200B-001, IRN-200B-004, IRN-200B-005, and IRN-200B-006 of ICD-GPS-200B. The principal reason for these exceptions is that Martin Marietta's contract does not include requirements for Extended Navigation, User Range Accuracy bin structure, some aspects of the Time of Almanac requirements and the Spherical Error Probability of the navigation signals received by the navigation users. Detailed reasons for these exceptions are given below.

1. Extended Navigation

Martin Marietta takes exception to the application of Extended Navigation (EN) requirements, or the attribution of EN performance or EN performance verification to the Block IIR SV. Such application or attribution may inadvertently be construed from the overall context.

The Block IIA operational mode called Long Term Extended Operations/"Extended Navigation" is undefined and not required in the Block IIR contract. There is no Block IIR requirement to support 180 days in the Block IIA mode without regular CS contacts and uploads. The Block IIR contract defines the Block IIA mode in the context of ICD-GPS-200B dated 30 November 1987 which describes a 14 day autonomy capability.

Figure 10-1. Letters of Exception (sheet 11 of 15)

IRN-200C-002
ICD-GPS-200C
25 SEP 1997

The Block IIR design supports 180 day autonomy in the context of the Autonomous Navigation mode and 14 day autonomy in the Block IIA mode. It may be possible to construct upload databases that will allow operation beyond 14 days with the current design, but this is not a current requirement. The Block IIR Space Vehicle does not support such an upload design, performance description, and performance verification.

Section 20.3.2, sentence 2 states "Block IIR SVs are designed to have sufficient memory to store 182 days of upload NAV data in the Block IIA mode ..." Martin Marietta takes exception to a "182 day" NAV data storage requirement in the Block IIA mode. The Block IIR design and validation plan is required to provide performance and memory margin computed on 14 day storage in the IIA mode as defined in Section 20.3.4.4 and 20.3.4.5 of the ICD-GPS-200B dated 30 November 1987.

Sections 20.3.4.4 and 20.3.4.5 with new Tables 20-XII and 20-XIII, define different "days spanned", "fit intervals", and "transmission intervals" compared to the 30 November 1987 ICD-GPS-200B. These changes are generated by some of the Extended Navigation upload characteristics for the Block IIA SV which supports "182 days" of data. Martin Marietta takes exception to evaluation and validation of the Block IIR design performance under these modified sections and tables.

2. URA Bin Structure

Martin Marietta takes exception to items relating to URA index to ranges of URA in meters appears to require the Block IIR SV in the Autonomous Navigation (AN) mode to transition from on index to the next at exactly the values of URA indicated. This specification of URA bins is not a defined requirement for Block IIR. The Block IIR AN design is based on the equations and the 'no better than' descriptions present in ICD-GPS-200B, in accordance with the Block IIR implementation.

When in the AN mode, the Martin Marietta design estimates URA on board the SV and converts the result to the index in the NAV user message by rearranging the equations and solving for the index. As a result, our design approximates, but does not exactly match, the description when Block IIR is in the AN mode.

When Block IIR is in the IIA mode, the Martin Marietta design does match the URA bin description exactly because we broadcast the index uploaded from the CS and the CS estimates URA.

3. Spherical Error Probable (SEP)

Martin Marietta takes exception to the URE statement in 6.3.4 since it implies Martin Marietta responsibility to relate Block IIR URE to 16 meters SEP.

Figure 10-1. Letters of Exception (sheet 12 of 15)

IRN-200C-002
ICD-GPS-200C
25 SEP 1997

17 August 1994
GPS IIR-CM-1046
Page 3

IRN-200B-006 added section 6.3.4 on "Autonomous Navigation Mode." The third sentence states that the Block IIR SV in the Autonav mode "... will have a user range error that is at or below a level required to support 16 meter SEP accuracy." The Block IIR SV constellation, when authorized to operate in the Autonav mode, is required to provide 6 meters (1 sigma) URE. The 6 meter requirement is defined in SV Segment Specification (SS-SS-500). Martin Marietta has been advised that this independently derived 6 meter URE requirement does support the 16 meter SEP system requirement for a nominal geometric dilution of precision. The 16 meter SEP accuracy in the user equipment output is dependent on geometry of the SVs chosen by the URE for the solution. The 16 meter SEP accuracy is not a requirement for Block IIR Space Vehicle.

4. Time of Almanac (Toa)

Martin Marietta takes exception to paragraph 20.3.3.5.2.2, since it implies that the SV is required to ensure that time of almanac (Toa) values be the same for a given data set (when the SV health is changed by the CS) or that Toa differ for successive data sets (which contain changes in SV health). This is a CS responsibility.

Martin Marietta is concerned about the ambiguous CS/SV requirement to ensure that the described Toa values are presented to Users in Appendix II, paragraph 20.3.3.5.2.2.

ICD-GPS-200, Revision C deletes 'The CS shall ensure' in paragraph 20.3.3.5.2.2. This is a change from ICD-GPS-200B dated 11/30/87 which is applied to our contract. If so deleted, ICD-GPS-200B will be mute as to who ensures that "All Toa values in SF4&5 shall be the same for a given almanac data set and shall differ for successive data sets which contain changes in almanac parameters or SV health.'

The Block IIR design is not required to, and does not, affect or check Toa based on the SV health settings described by this section. The Block IIR design depends on CS uploads for SV health and the relationship of SV health data to almanac reference time.

In an independent process, CS uploads for Toa values and almanacs are inputs to the on-board generation of Toa values when the Block IIR design propagates almanacs to remain within 3.5 days of GPS time. If the CS provides a valid upload, the Block IIR on-board processing will maintain that all Toa values in SF4&5 will be the same for a given almanac data set and will differ for successive data sets which contain changes in almanac parameters.

Figure 10-1. Letters of Exception (sheet 13 of 15)

IRN-200C-002
ICD-GPS-200C
25 SEP 1997

UNCLASSIFIED

17 August 1994
GPS IIR-CM-1046
Page 4

Specific Exceptions

In addition, Martin Marietta takes exceptions to the specific requirements listed below:

Paragraph #	Description
20.3.3.3.1.1	Change of week number: Extended Navigation (EN).
Table 20-V	SV ID Nos. in Note 4 (EN).
6.2.3 - 6.2.3.3	Definitions. CS responsibility. N/A to Block-IIR.
6.3.2, 6.3.3	Extended Navigation Mode description.
6.3.4	"... and will have ... 16 meter SEP accuracy."
6.3.4	Orbit parameters. Narrative on almanac. N/A to Block-IIR.
	Martin Marietta uses ICD-GPS-401 method.
20.3.2	"... 182 days of uploaded NAV data in the Block IIA ..."
20.3.2	"(d) if a control ... subframes will indicate ID = 1 ..."
	IRN excludes Block-IIR.
20.3.3.4.1	CS requirement deleted. (Related to extended nav.).
20.3.3.5.1.2	Propagation of Toa requirements.
20.3.3.5.1.2	"For Block II ... transmission interval."
20.3.3.5.2.2	Propagation of Toa requirements.
20.3.4.1	Reqmt for subframe changes at frame boundary.
20.3.4.4	Table 20-XII: Ext. Nav related.
Table 20-XII	IODC Requirements. Ext. Nav related.
20.3.4.4	Two hour data sets are not tested.
Table 20-XII	Transmission intervals. Ext. Nav related.

Note that if Martin Marietta has taken earlier exception to a change in any requirements in a previous revision of this document, Martin Marietta continues to take exception to that change. The retraction of an exception will be accomplished by a letter explicitly stating that the exception is no longer valid.

If there are any questions of a technical nature concerning the contents of this letter, please contact Dave Levin at (610) 354-3022. All other questions or comments should be addressed to the undersigned at (610) 354-1710.

Very truly yours,
MARTIN MARIETTA ASTRO SPACE

Signature on file
D. Supow
Manager, GPS Contracts
GPS PMO

cc: Maj. Paul Schubert (CZEP)

/dd

Figure 10-1. Letters of Exception (sheet 14 of 15)

IRN-200C-002
ICD-GPS-200C
25 SEP 1997

UNCLASSIFIED

Lockheed Martin Federal Systems, Inc.
700 N. Frederick Avenue Gaithersburg, MD 20879-3328
Telephone 301-240-7500



In reply refer to: GOSC96000912

September 5, 1996

ARINC Research Corporation
2250 E. Imperial Highway, Suite 450
El Segundo, CA 90245-3509

Attention: Mr. Soon K. Yi

Subject: PIRN-200C-002

Reference: 1. Contract F04606-95-D-0239
2. ARINC letter RO/SMS/ES/SE/96-025, dated July 9, 1996

Dear Mr. Yi:

PIRN-200C-002 has been reviewed by Lockheed Martin Federal Systems, the Control Segment Contractor. This PIRN is approved subject to the contractual exception below:

The changes contained in this PIRN are not within the baseline of our GPS OCS Support Contract.

Enclosed is the signed approval sheet requested in the referenced letter.

If you have any questions, please contact Ming Kang Chien at (301)240-6449.

Very truly yours,

Signature on file
C. T. Thomas
Contract Administrator

Enclosure

cc: Maj. P. Schubert	SMC/CZGD
Capt. F. Wylie	SMC/CZEA
Capt. J. Gravitt	SMC/CZE
Capt. J. Varljen	SMC/CZEP
D. Munk	SMC/CZGP
D. Greer	SM-ALC/PKLX

Figure 10-1. Letters of Exception (sheet 15 of 16).

**IRN-200C-003
ICD-GPS-200C
11 OCT 1999**

Government Systems
350 Collins Road NE
Cedar Rapids, Iowa 52498
Tel. 319.295.1000

**Rockwell
Collins**

August 27, 1999

ARINC Incorporated
2250 East Imperial Highway, Suite 450
El Segundo, CA 90245-3509

Attention: Mr. Soon K. Yi

Reference: ARINC memo ATE/SMS/OPS/GJP/99-038, dated 28 July 99

Dear Mr. Yi:

Subject: Rockwell Collins, Inc. Letter of Exception against PIRN-200C-003
Revision A, as defined by the referenced ARINC memo

The subject PIRN documents the use of an Earth Centered Inertial (ECI) frame to define the location of the satellites and account for satellite motion during signal transit time. There are also numerous typo corrections. Also the Navigation Message Correction Term (NMCT), also commonly referred to as WAGE, is partially covered.

Rockwell Collins approves this PIRN with the following exceptions:

- 1) Implementation of older style corrections for satellite motion during signal transit time (paragraph 20.3.3.4.3.3 and 20.3.3.4.3.4) shall be permitted in User Equipment.
- 2) Use of NMCT data (paragraph 20.3.3.5.2.6) is not mandatory and will be determined by the manufacturers of User Equipment, based on required accuracy.

Sincerely,

Signature on file
A. Caslavka, Director
Navigation Systems

js

Figure 10-1. Letters of Exception (sheet 16 of 16).

**IRN-200C-003
ICD-GPS-200C
11 OCT 1999**

UNCLASSIFIED

Lockheed Martin Space Systems Company
Space & Strategic Missiles
Valley Forge Operations
P.O. Box 8555 Philadelphia, PA 19101



26 May 2003
GPS IIR-CM-MOD-147

SMC/CZK
2420 VELA WAY, SUITE 1467
LOS ANGELES AFB CA 90245-4659

Attention: Mr. David Smith

Subject: GPS Block IIR Modernization Contract F04701-00-C-0006
Review and approval of ICD-GPS-PIRN-200C-007B, dated 08 November 2003, post 9
April 2003 CCB (L2C = -160).

Reference: 1) PCOL# 03-012, dated 22 May 03; F04701-00-C-0006; REQUEST FOR IMPACTS
DUE TO IMPLEMENTING PROPOSED CHANGES TO PIRN-200C-007
REVISION B

Dear Mr. Smith:

Lockheed Martin Space Systems Company has been asked to review and comment on changes made to ICD-GPS-PIRN-200C-007B at the JPO CCB boarded on or about 09 April 2003. It is our understanding that the ONLY change made to the 08 November 2002 of the subject ICD is L2C for IIR-M SVs changed from -161.4 dBW to -160.0 dBW.

Based on that change, Lockheed Martin takes exception to IIR-M L2 C signal power specified in Table 3-III. Per Lockheed Martin contract requirements as specified in SS-SS-500, Rev. A, dated 14 May 2001, LMSSC calculates links using:

- 0-dBi circularly polarized user receiving antenna (located) near ground when the SV is above a 5° elevation angle
- Atmospheric loss of 0.5 dB at edge of earth
- Assumes SV antenna gains are averaged about azimuth

Using the assumptions as specified in paragraph 3.3.1.6 of PIRN-200C-007B, the GPS IIRM SVs provide a minimum receive signal of -161.4 dBW for L2 C signal. Lockheed Martin therefore takes exception to -160 dBW for L2C of PIRN-200c-007B. Formal request for cost and schedule impacts should come through the JPO Contracting Officer.

To change from -161.4 dBW to -160.0 dBW would have to be analyzed and coordinated between Lockheed Martin and ITT. If such a change were technically possible, there would be impacts to L-Band level testing, SV level testing, test scripts, Specs, OOH, and various ICDs. These impacts would be in both cost and schedule.

Figure 10-1. Letters of Exception (sheet 17 of 18).

IRN-200C-005R1
ICD-GPS-200C
14 Jan 2003

GPS IIR-CM-MOD-147
Page 2

Currently, there is an ongoing effort between Lockheed Martin, Boeing, Arinc, Aerospace, and the JPO concerning signal flexibility under the ConOps study. Lockheed Martin recommends, based on the outcome and direction of this effort, that an impact to the ICD-200 change be included in the resulting request for ROMs for Flex Power implementation.

Note that if Lockheed Martin has taken earlier exception to a change in any requirements in a previous revision of this document, Lockheed Martin continues to take exception to that change. A letter explicitly stating that the exception is no longer valid will accomplish the retraction of an exception.

Should you have any questions, please contact Martin O'Connor at (610) 354-7866 for technical concerns, or the undersigned at (610) 354-7989 for contractual matters.

Very truly yours,

LOCKHEED MARTIN CORPORATION

Signature on file

Brent B. Achee II
GPS Block IIR Deputy Program Director

xc: Capt. K. Eggehorn
Mary Guyes
Soon Yi, ARINC
J. Windfelder, DCMC

Figure 10-1. Letters of Exception (sheet 18 of 18).

IRN-200C-005R1
ICD-GPS-200C
14 Jan 2003

20. APPENDIX II. GPS NAVIGATION DATA STRUCTURE FOR DATA, D(t)

20.1 Scope. This appendix describes the specific GPS navigation (NAV) data structure denoted as D(t). When transmitted as part of the NAV data, D(t), the specific data structure of D(t) shall be denoted by data ID number 2, represented by the two-bit binary notation as 01.

20.2 Applicable Documents.

20.2.1 Government Documents. In addition to the documents listed in paragraph 2.1, the following documents of the issue specified contribute to the definition of the NAV data related interfaces and form a part of this Appendix to the extent specified herein.

Specifications

None

Standards

None

Other Publications

None

20.2.2 Non-Government Documents. In addition to the documents listed in paragraph 2.2, the following documents of the issue specified contribute to the definition of the NAV data related interfaces and form a part of this Appendix to the extent specified herein.

Specifications

None

Other Publications

None

20.3 Requirements

20.3.1 Data Characteristics. The data stream shall be transmitted by the SV on the L1 and L2 channels at a rate of 50 bps. In addition, upon ground command, the data stream shall be transmitted by the Block IIR-M SV on the L2 CM channel at a rate of 25 bps using FEC encoding resulting in 50 sps.

20.3.2 Message Structure. As shown in Figure 20-1, the message structure shall utilize a basic format of a 1500 bit long frame made up of five subframes, each subframe being 300 bits long. Subframes 4 and 5 shall be subcommutated 25 times each, so that a complete data message shall require the transmission of 25 full frames. The 25 versions of subframes 4 and 5 shall be referred to herein as pages 1 through 25 of each subframe. Each subframe shall consist of ten words, each 30 bits long; the MSB of all words shall be transmitted first.

Each subframe and/or page of a subframe shall contain a telemetry (TLM) word and a handover word (HOW), both generated by the SV, and shall start with the TLM/HOW pair. The TLM word shall be transmitted first, immediately followed by the HOW. The latter shall be followed by eight data words. Each word in each frame shall contain parity (reference Section 20.3.5).

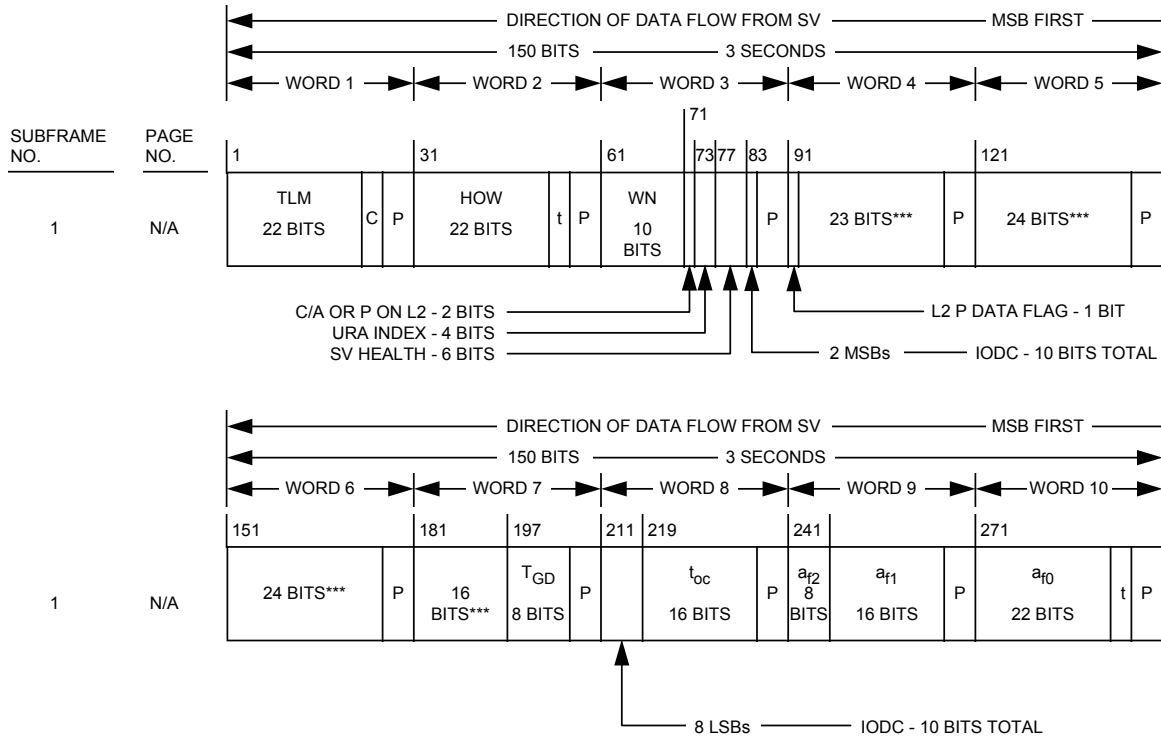

*** RESERVED
 P = 6 PARITY BITS
 t = 2 NONINFORMATION BEARING BITS USED FOR PARITY COMPUTATION (SEE PARAGRAPH 20.3.5)
 C = TLM BITS 23 AND 24 WHICH ARE RESERVED

Figure 20-1. Data Format (sheet 1 of 11)

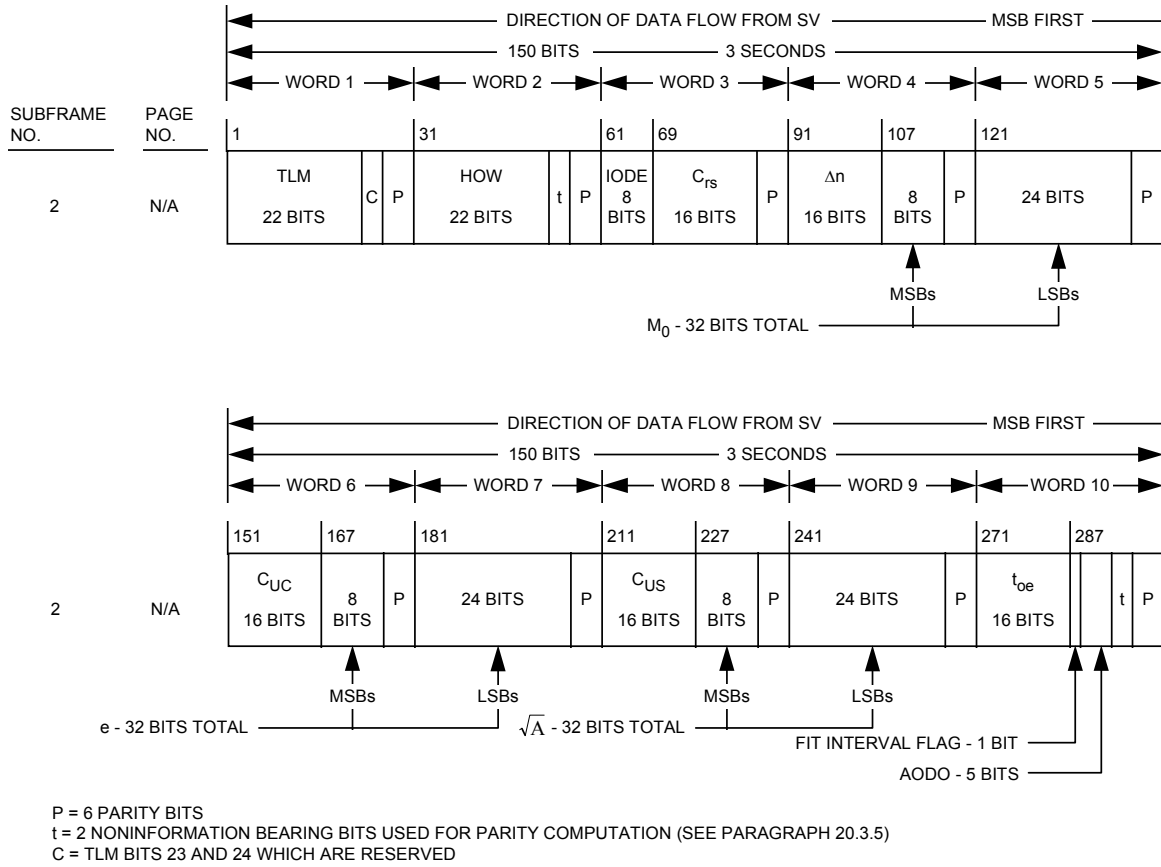
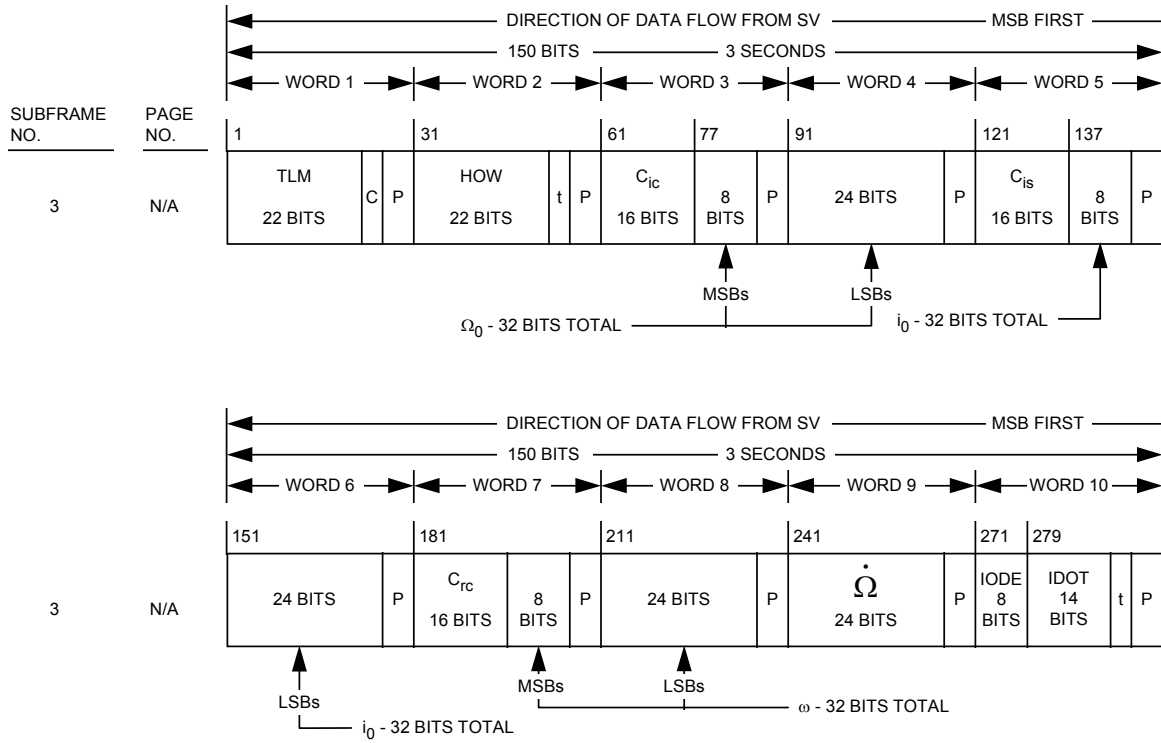
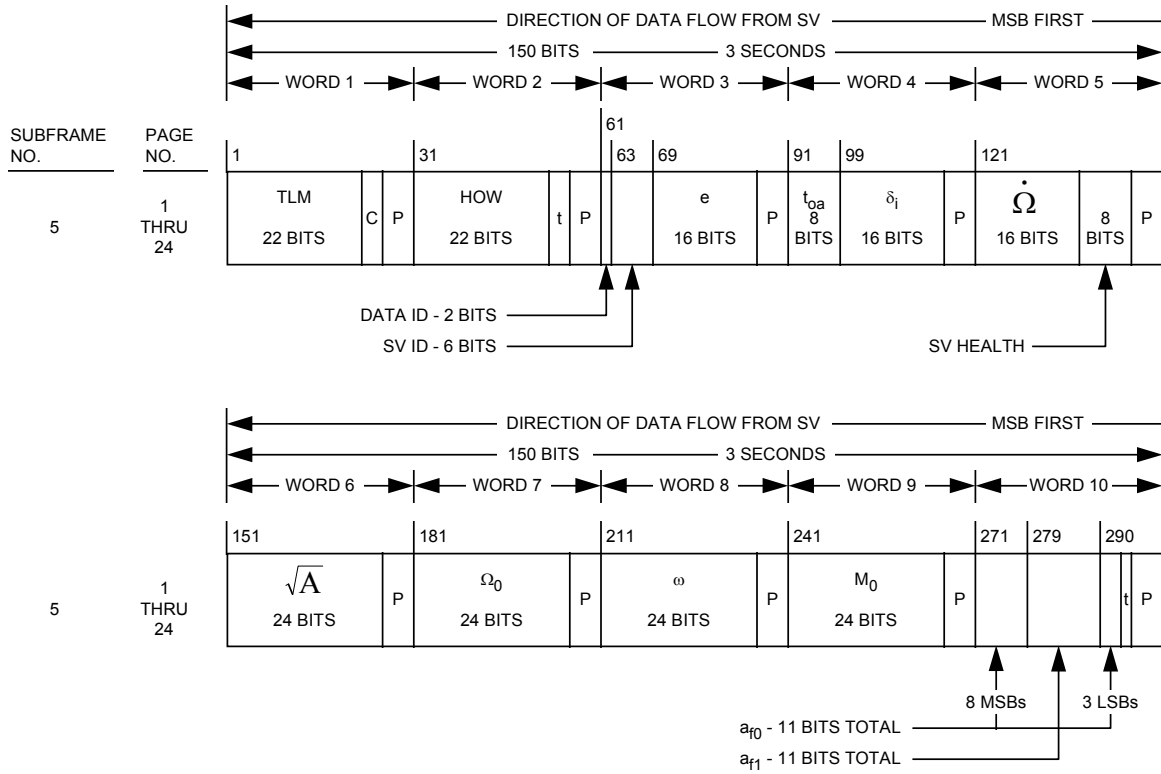

Figure 20-1. Data Format (sheet 2 of 11)



P = 6 PARITY BITS
 t = 2 NONINFORMATION BEARING BITS USED FOR PARITY COMPUTATION (SEE PARAGRAPH 20.3.5)
 C = TLM BITS 23 AND 24 WHICH ARE RESERVED

Figure 20-1. Data Format (sheet 3 of 11)



P = 6 PARITY BITS
 t = 2 NONINFORMATION BEARING BITS USED FOR PARITY COMPUTATION (SEE PARAGRAPH 20.3.5)
 C = TLM BITS 23 AND 24 WHICH ARE RESERVED
 NOTE: PAGES 2, 3, 4, 5, 7, 8, 9 & 10 OF SUBFRAME 4 HAVE THE SAME FORMAT AS PAGES 1 THROUGH 24 OF SUBFRAME 5

Figure 20-1. Data Format (sheet 4 of 11)

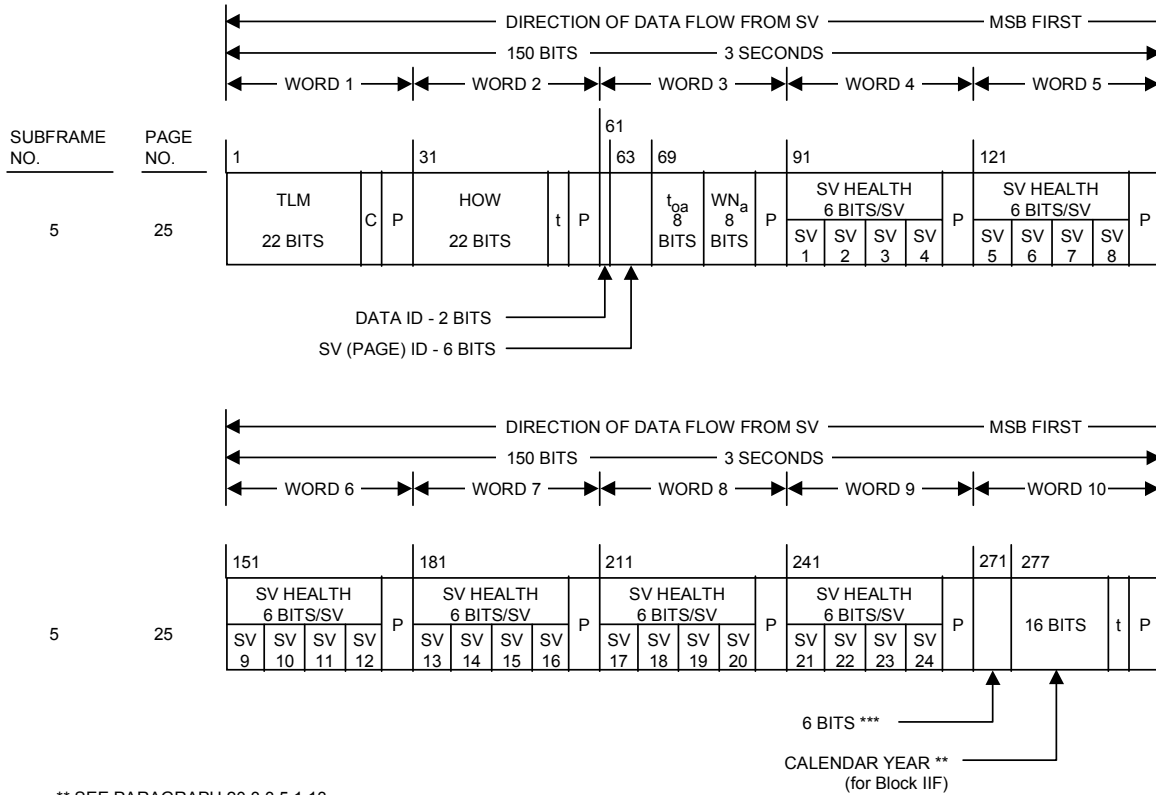

** SEE PARAGRAPH 20.3.3.5.1.13
 *** RESERVED
 P = 6 PARITY BITS
 t = 2 NONINFORMATION BEARING BITS USED FOR PARITY COMPUTATION (SEE PARAGRAPH 20.3.5)
 C = TLM BITS 23 AND 24 WHICH ARE RESERVED

Figure 20-1. Data Format (sheet 5 of 11)

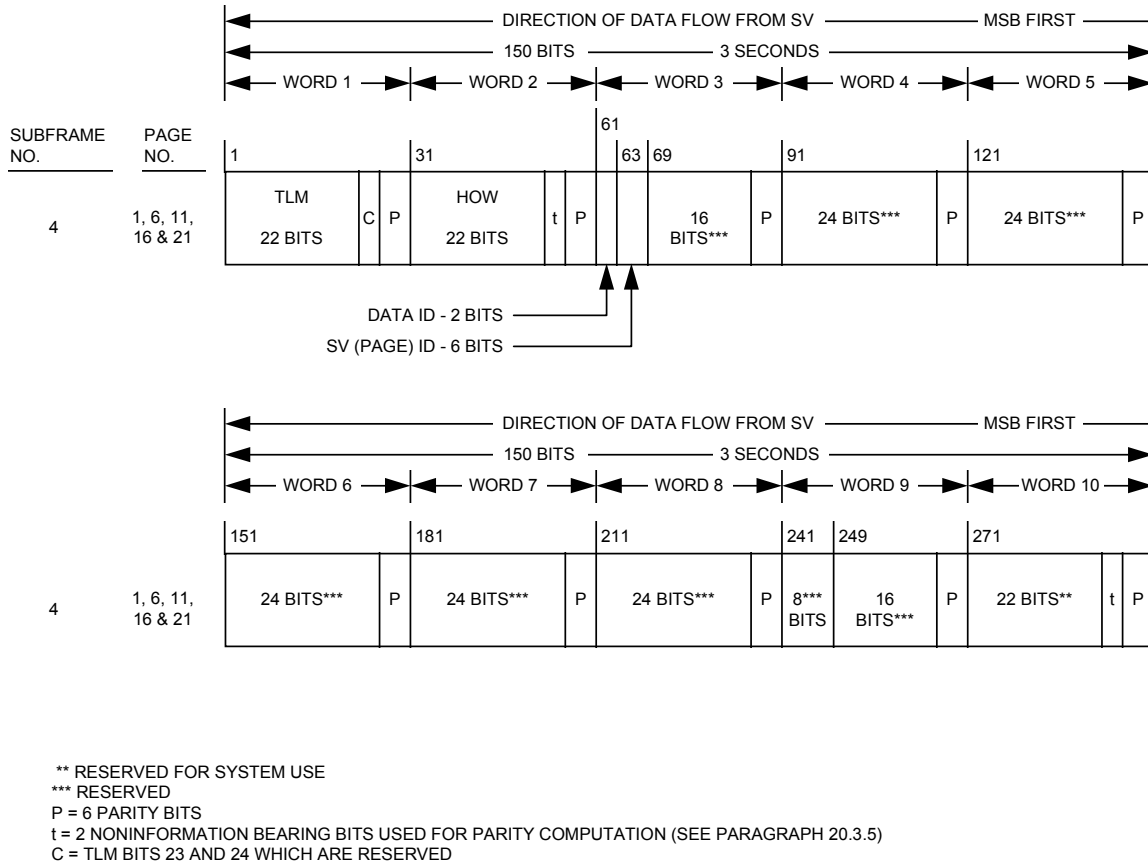
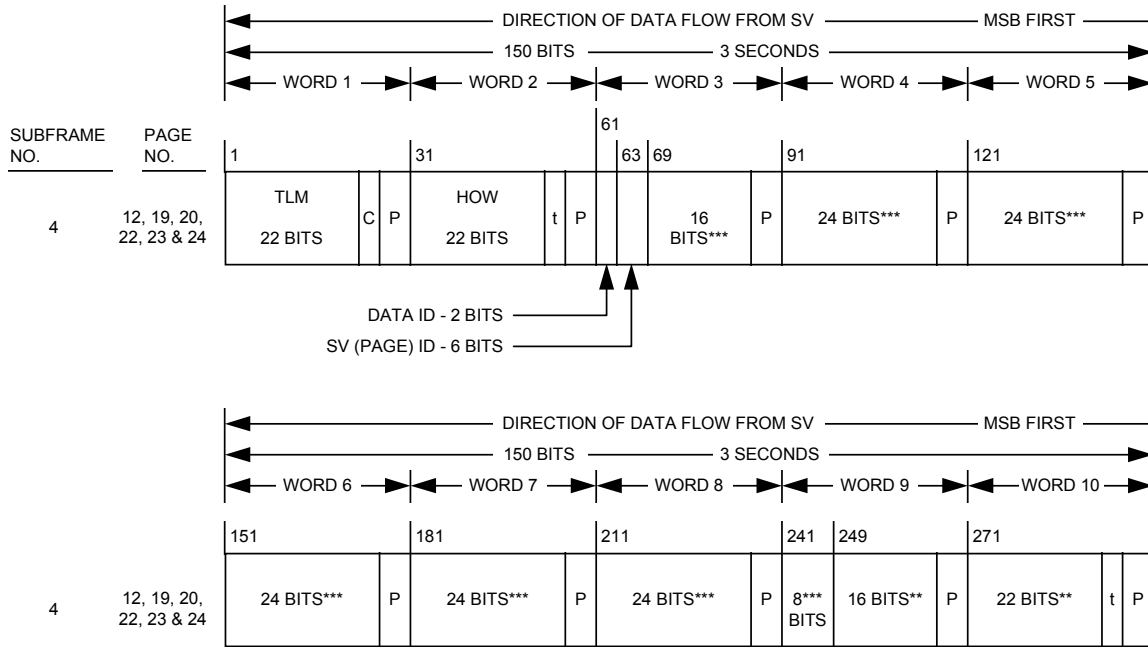
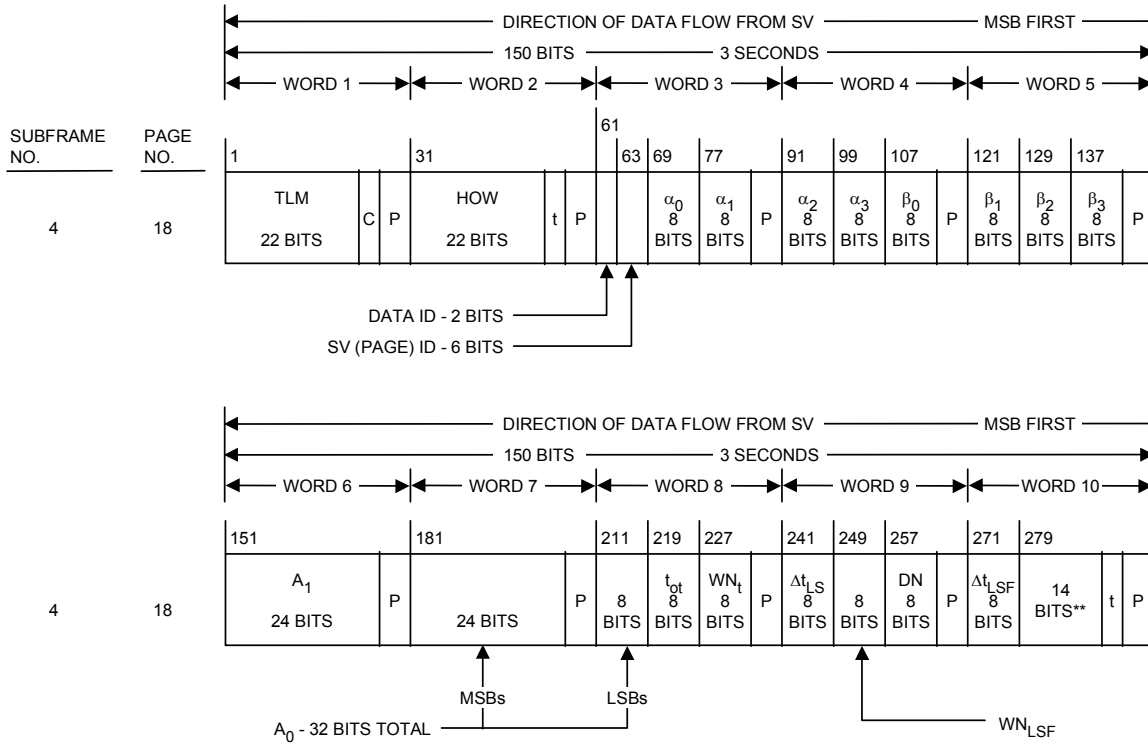

Figure 20-1. Data Format (sheet 6 of 11)



** RESERVED FOR SYSTEM USE
 *** RESERVED
 P = 6 PARITY BITS
 t = 2 NONINFORMATION BEARING BITS USED FOR PARITY COMPUTATION (SEE PARAGRAPH 20.3.5)
 C = TLM BITS 23 AND 24 WHICH ARE RESERVED

Figure 20-1. Data Format (sheet 7 of 11)



** RESERVED FOR SYSTEM USE
 P = 6 PARITY BITS
 t = 2 NONINFORMATION BEARING BITS USED FOR PARITY COMPUTATION (SEE PARAGRAPH 20.3.5)
 C = TLM BITS 23 AND 24 WHICH ARE RESERVED

Figure 20-1. Data Format (sheet 8 of 11)

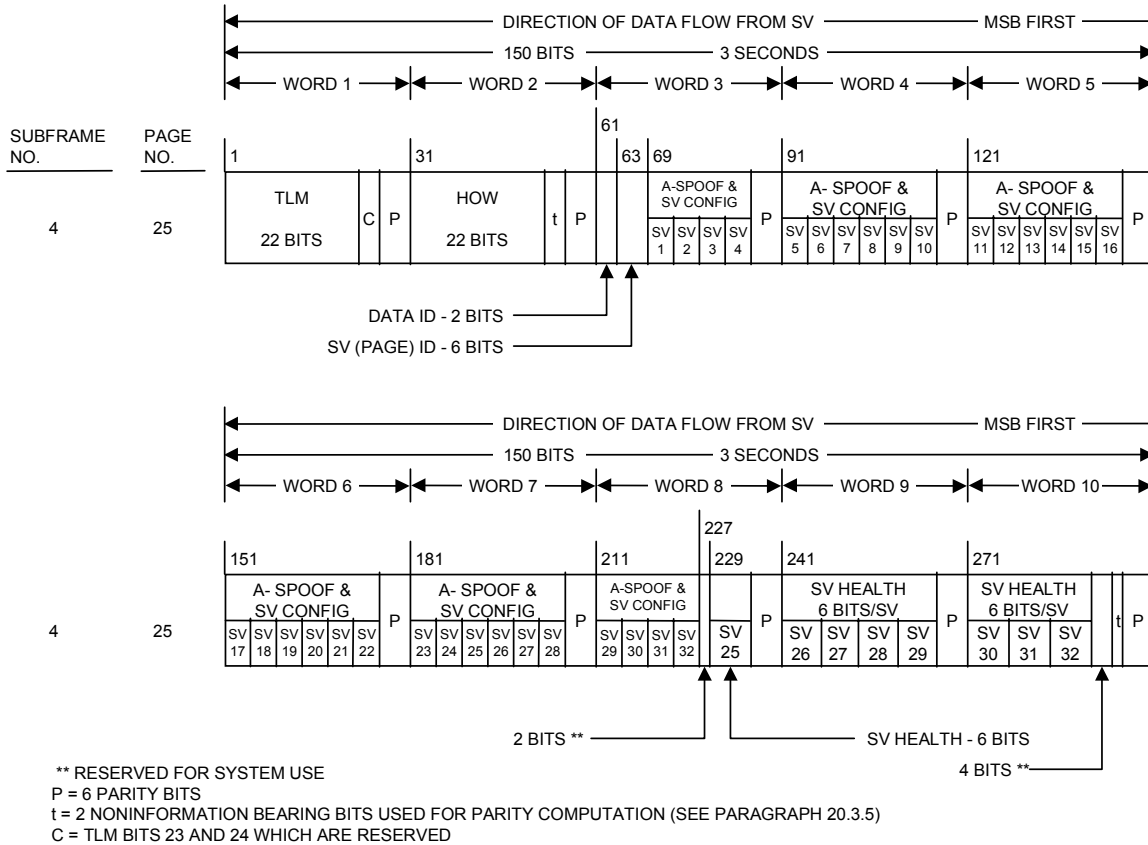
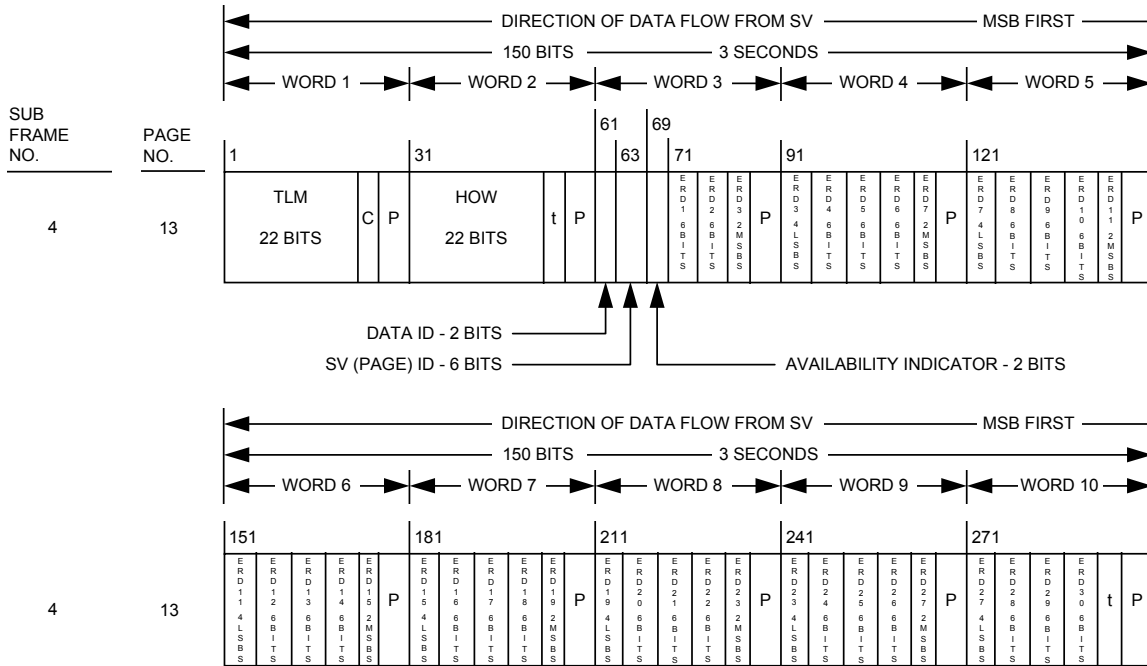
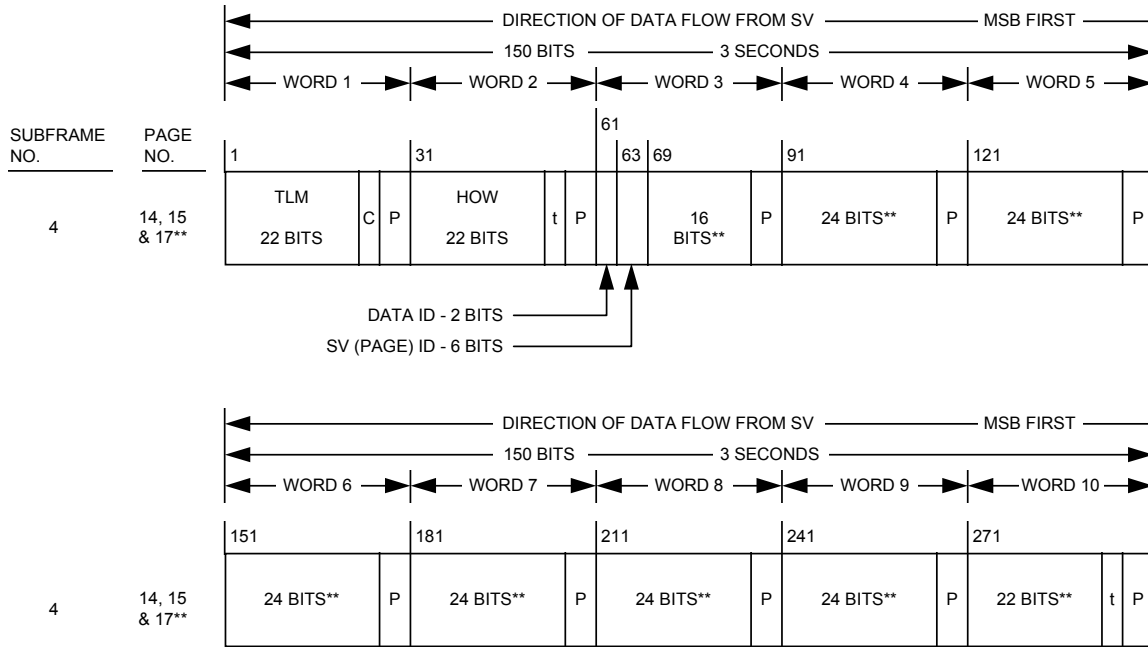

Figure 20-1. Data Format (sheet 9 of 11)



P = 6 PARITY BITS
 t = 2 NONINFORMATION BEARING BITS USED FOR PARITY COMPUTATION (SEE PARAGRAPH 20.3.5)
 C = TLM BITS 23 AND 24 WHICH ARE RESERVED

Figure 20-1. Data Format (sheet 10 of 11)



** THE INDICATED PORTIONS OF WORDS 3 THROUGH 10 OF PAGES 14 AND 15 ARE RESERVED FOR SYSTEM USE, WHILE THOSE OF PAGE 17 ARE RESERVED FOR SPECIAL MESSAGES PER PARAGRAPH 20.3.3.5.1.10
 P = 6 PARITY BITS
 t = 2 NONINFORMATION BEARING BITS USED FOR PARITY COMPUTATION (SEE PARAGRAPH 20.3.5)
 C = TLM BITS 23 AND 24 WHICH ARE RESERVED

Figure 20-1. Data Format (sheet 11 of 11)

UNCLASSIFIED

(This page intentionally left blank.)

**IRN-200C-002
ICD-GPS-200C
25 SEP 1997**

76b

UNCLASSIFIED

UNCLASSIFIED

Block II and IIA SVs are designed with sufficient memory capacity for storing 182 days of uploaded NAV data. However, the memory retention of these SVs will determine the duration of data transmission. Block IIR SVs are designed to have sufficient memory to store 182 days of uploaded NAV data in the Block IIA mode and to store 210 days of CS data needed to generate NAV data on-board in the Autonav mode. Alternating ones and zeros will be transmitted in words 3 through 10 in place of the normal NAV data whenever the SV cannot locate the requisite valid control or data element in its on-board computer memory. The following specifics apply to this default action: (a) the parity of the affected words will be invalid, (b) the two trailing bits of word 10 will be zeros (to allow the parity of subsequent subframes to be valid -- reference paragraph 20.3.5), (c) if the problem is the lack of a data element, only the directly related subframe(s) will be treated in this manner, (d) if a control element cannot be located, this default action will be applied to all subframes and all subframes will indicate ID = 1 (Block II/IIA only) (i.e., an ID-code of 001) in the HOW (reference paragraph 20.3.3.2) (Block IIR/IIR-M and IIF SVs indicate the proper subframe ID for all subframes). Certain failures of control elements which may occur in the SV memory or during an upload will cause the SV to transmit in non-standard codes (NSC and NSY) which would preclude normal use by the US. Normal NAV data transmission will be resumed by the SV whenever a valid set of elements becomes available.

IRN-200C-005R1
ICD-GPS-200C
14 Jan 2003

UNCLASSIFIED

UNCLASSIFIED

Block II SVs are uploaded with 182 days of NAV data. However, the EAROM retentivity for these SVs is designed and guaranteed for only 14 days. Therefore, Block II SV memory is most likely to fail sometime during long-term extended operations after repeated write operations. In the case of memory failure, the SV will transmit alternating ones and zeros in word 3-10 as specified in the above paragraph.

Block IIA SVs are also uploaded with 182 days of data. However, the EAROM retentivity for these SVs is designed and guaranteed for 180 days.

The memory retentivity for the Block IIR/IIR-M SVs is designed and guaranteed for 210 days.

The memory retentivity for the Block IIF SVs is designed and guaranteed for 90 days.

Although the data content of the SVs will be temporarily reduced during the upload process, the transmission of valid NAV data will be continuous. The data capacity of specific operational SVs may be reduced to accommodate partial memory failures.

IRN-200C-005R1
ICD-GPS-200C
14 Jan 2003

20.3.3 Message Content. The format and contents of the TLM word and the HOW, as well as those of words three through ten of each subframe/page, are described in the following subparagraphs. The timing of the subframes and pages is covered in Section 20.3.4.

20.3.3.1 Telemetry Word. Each TLM word is 30 bits long, occurs every six seconds in the data frame, and is the first word in each subframe/page. The format shall be as shown in Figure 20-2. Bit 1 is transmitted first. Each TLM word shall begin with a preamble, followed by the TLM message, two reserved bits, and six parity bits. The TLM message contains information needed by the authorized user and by the CS, as described in the related SS/CS interface documentation.

20.3.3.2 Handover Word (HOW). The HOW shall be 30 bits long and shall be the second word in each subframe/page, immediately following the TLM word. A HOW occurs every 6 seconds in the data frame. The format and content of the HOW shall be as shown in Figure 20-2. The MSB is transmitted first. The HOW begins with the 17 MSBs of the time-of-week (TOW) count. (The full TOW count consists of the 19 LSBs of the 29-bit Z-count). These 17 bits correspond to the TOW-count at the X1 epoch which occurs at the start (leading edge) of the next following subframe (reference paragraph 3.3.4).

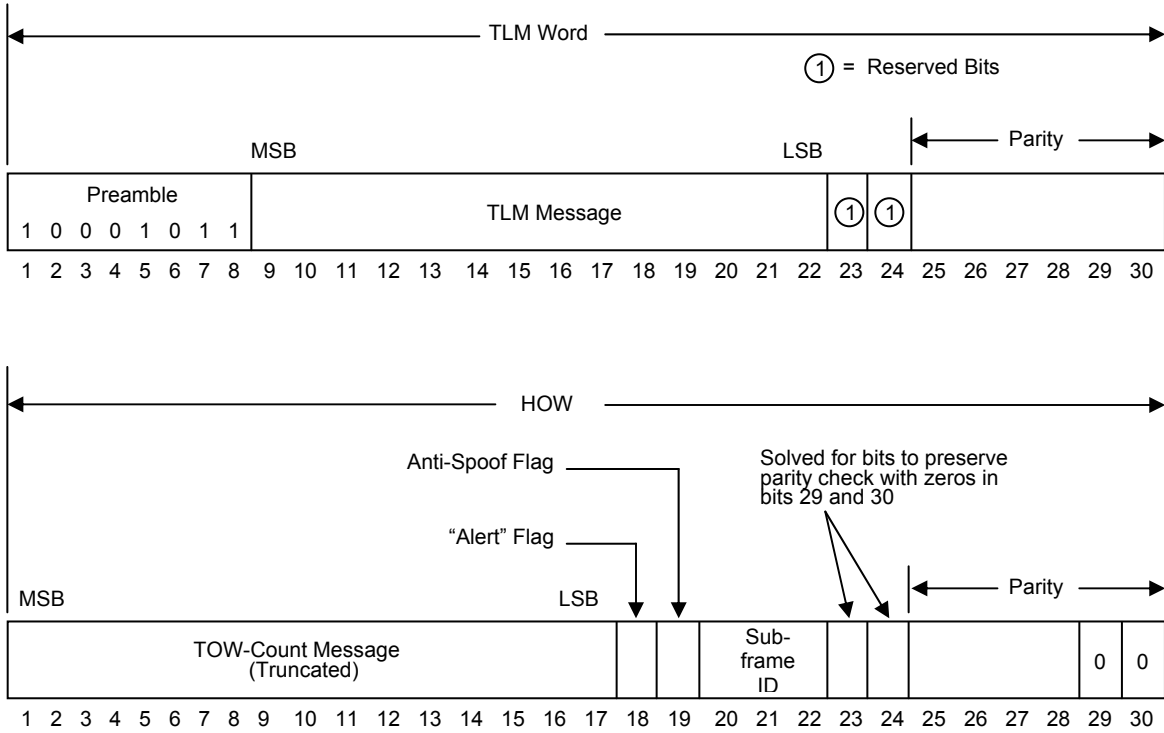

Figure 20-2. TLM and HOW Formats

UNCLASSIFIED

Bit 18 is an "alert" flag. When this flag is raised (bit 18 = "1"), it shall indicate to the unauthorized user that the SV URA may be worse than indicated in subframe 1 and that he shall use that SV at his own risk.

Bit 19 is an anti-spoof (A-S) flag. A "1" in bit-position 19 indicates that the A-S mode is ON in that SV.

Bits 20, 21, and 22 of the HOW provide the ID of the subframe in which that particular HOW is the second word; the ID code shall be as follows:

<u>Subframe</u>	<u>ID Code</u>
1	001
2	010
3	011
4	100
5	101

IRN-200C-005R1
ICD-GPS-200C
14 Jan 2003

20.3.3.3 Subframe 1. The content of words three through ten of subframe 1 are defined below, followed by related algorithms and material pertinent to use of the data.

20.3.3.3.1 Subframe 1 Content. The third through tenth words of subframe 1 shall each contain six parity bits as their LSBs; in addition, two non-information bearing bits shall be provided as bits 23 and 24 of word ten for parity computation purposes. The remaining 190 bits of words three through ten shall contain the clock parameters and other data described in the following.

The clock parameters describe the SV time scale during the period of validity. The parameters in a data set shall be valid during the interval of time in which they are transmitted and shall remain valid for an additional period of time after transmission of the next data set has started. The timing information for subframes, pages, and data sets is covered in Section 20.3.4.

20.3.3.3.1.1 Transmission Week Number. The ten MSBs of word three shall contain the ten MSBs of the 29-bit Z-count as qualified herein. These ten bits shall be a Modulo 1024 binary representation of the current GPS week number at the start of the data set transmission interval (see paragraph 3.3.4(b)). The GPS week number increments at each end/start of week epoch. For Block II SVs in long-term extended operations, beginning approximately 28 days after upload, the transmission week number may not correspond to the actual GPS week number due to curve fit intervals that cross week boundaries.

20.3.3.3.1.2 Code(s) on L2 Channel. Bits 11 and 12 of word three shall indicate which code(s) is (are) commanded ON for the L2 channel, as follows:

- 00 = Reserved,
- 01 = P code ON,
- 10 = C/A code ON.

20.3.3.3.1.3 SV Accuracy. Bits 13 through 16 of word three shall give the URA index of the SV (reference paragraph 6.2.1) for the unauthorized user. The URA index (N) is an integer in the range of 0 through 15 and has the following relationship to the URA of the SV:

<u>URA INDEX</u>	<u>URA (meters)</u>		
0	0.00	< URA ≤	2.40
1	2.40	< URA ≤	3.40
2	3.40	< URA ≤	4.85
3	4.85	< URA ≤	6.85
4	6.85	< URA ≤	9.65
5	9.65	< URA ≤	13.65
6	13.65	< URA ≤	24.00
7	24.00	< URA ≤	48.00
8	48.00	< URA ≤	96.00
9	96.00	< URA ≤	192.00
10	192.00	< URA ≤	384.00
11	384.00	< URA ≤	768.00
12	768.00	< URA ≤	1536.00
13	1536.00	< URA ≤	3072.00
14	3072.00	< URA ≤	6144.00
15	6144.00	< URA	(or no accuracy prediction is available - unauthorized users are advised to use the SV at their own risk.)

UNCLASSIFIED

For each URA index (N), users may compute a nominal URA value (X) as given by:

- If the value of N is 6 or less, $X = 2^{(1+N/2)}$,
- If the value of N is 6 or more, but less than 15, $X = 2^{(N-2)}$,
- N = 15 shall indicate the absence of an accuracy prediction and shall advise the unauthorized user to use that SV at his own risk.

For N = 1, 3, and 5, X should be rounded to 2.8, 5.7, and 11.3 meters, respectively.

20.3.3.3.1.4 SV Health. The six-bit health indication given by bits 17 through 22 of word three refers to the transmitting SV. The MSB shall indicate a summary of the health of the NAV data, where

0 = all NAV data are OK,

1 = some or all NAV data are bad.

The five LSBs shall indicate the health of the signal components in accordance with the codes given in paragraph 20.3.3.5.1.3. The health indication shall be given relative to the "as designed" capabilities of each SV (as designated by the configuration code - see paragraph 20.3.3.5.1.6). Accordingly, any SV which does not have a certain capability will be indicated as "healthy" if the lack of this capability is inherent in its design or if it has been configured into a mode which is normal from a user standpoint and does not require that capability.

Additional SV health data are given in subframes 4 and 5. The data given in subframe 1 may differ from that shown in subframes 4 and/or 5 of other SVs since the latter may be updated at a different time.

20.3.3.3.1.5 Issue of Data, Clock (IODC). Bits 23 and 24 of word three in subframe 1 shall be the two MSBs of the ten-bit IODC term; bits one through eight of word eight in subframe 1 shall contain the eight LSBs of the IODC. The IODC indicates the issue number of the data set and thereby provides the user with a convenient means of detecting any change in the correction parameters. Constraints on the IODC as well as the relationship between the IODC and the IODE (issue of data, ephemeris) terms are defined in paragraph 20.3.4.4.

Short-term and Long-term Extended Operations. Whenever the fit interval flag indicates a fit interval greater than 4 hours, the IODC can be used to determine the actual fit interval of the data set (reference section 20.3.4.4).

20.3.3.3.1.6 Data Flag for L2 P-Code. When bit 1 of word four is a "1", it shall indicate that the NAV data stream was commanded OFF on the P-code of the L2 channel.

20.3.3.3.1.7 (Reserved)

20.3.3.3.1.8 Estimated Group Delay Differential. Bits 17 through 24 of word seven contain the L1-L2 correction term, T_{GD} , for the benefit of "L1 only" or "L2 only" users; the related user algorithm is given in paragraph 20.3.3.3.3.

20.3.3.3.1.9 SV Clock Correction. Bits nine through 24 of word eight, bits one through 24 of word nine, and bits one through 22 of word ten contain the parameters needed by the users for apparent SV clock correction (t_{oc} , a_{f2} , a_{f1} , a_{f0}). The related algorithm is given in paragraph 20.3.3.3.3.

20.3.3.3.2 Subframe 1 Parameter Characteristics. For those parameters whose characteristics are not fully defined in Section 20.3.3.3.1, the number of bits, the scale factor of the LSB (which shall be the last bit received), the range, and the units shall be as specified in Table 20-I.

20.3.3.3.3 User Algorithms for Subframe 1 Data. The algorithms defined below (a) allow all users to correct the code phase time received from the SV with respect to both SV code phase offset and relativistic effects, (b) permit the "single frequency" (L1 or L2) user to compensate for the effects of SV group delay differential (the user who utilizes both frequencies does not require this correction, since the clock parameters account for the induced effects), and (c) allow the "two frequency" (L1 and L2) user to correct for the group propagation delay due to ionospheric effects (the single frequency user may correct for ionospheric effects as described in paragraph 20.3.3.5.2.5).

Table 20-I. Subframe 1 Parameters				
Parameter	No. of Bits**	Scale Factor (LSB)	Effective Range***	Units
Code on L2	2	1		discretes
Week No.	10	1		week
L2 P data flag	1	1		discrete
SV accuracy	4			(see text)
SV health	6	1		discretes
T _{GD}	8*	2 ⁻³¹		seconds
IODC	10			(see text)
t _{oc}	16	2 ⁴	604,784	seconds
a _{f2}	8*	2 ⁻⁵⁵		sec/sec ²
a _{f1}	16*	2 ⁻⁴³		sec/sec
a _{f0}	22*	2 ⁻³¹		seconds
<p>* Parameters so indicated shall be two's complement, with the sign bit (+ or -) occupying the MSB;</p> <p>** See Figure 20-1 for complete bit allocation in subframe;</p> <p>*** Unless otherwise indicated in this column, effective range is the maximum range attainable with indicated bit allocation and scale factor.</p>				

20.3.3.3.3.1 User Algorithm for SV Clock Correction. The polynomial defined in the following allows the user to determine the effective SV PRN code phase offset referenced to the phase center of the antennas (Δt_{sv}) with respect to GPS system time (t) at the time of data transmission. The coefficients transmitted in subframe 1 describe the offset apparent to the two-frequency user for the interval of time in which the parameters are transmitted. This estimated correction accounts for the deterministic SV clock error characteristics of bias, drift and aging, as well as for the SV implementation characteristics of group delay bias and mean differential group delay. Since these coefficients do not include corrections for relativistic effects, the user's equipment must determine the requisite relativistic correction. Accordingly, the offset given below includes a term to perform this function.

The user shall correct the time received from the SV with the equation (in seconds)

$$t = t_{sv} - \Delta t_{sv} \tag{1}$$

where

- t = GPS system time (seconds),
- t_{sv} = effective SV PRN code phase time at message transmission time (seconds),
- Δt_{sv} = SV PRN code phase time offset (seconds).

The SV PRN code phase offset is given by

$$\Delta t_{sv} = a_{f0} + a_{f1}(t - t_{oc}) + a_{f2}(t - t_{oc})^2 + \Delta t_r \tag{2}$$

where

a_{f0} , a_{f1} and a_{f2} are the polynomial coefficients given in subframe 1, t_{oc} is the clock data reference time in seconds (reference paragraph 20.3.4.5), and Δt_r is the relativistic correction term (seconds) which is given by

$$\Delta t_r = Fe(A)^{1/2} \sin E_k.$$

The orbit parameters (e, A, E_k) used here are described in discussions of data contained in subframes 2 and 3, while F is a constant whose value is

$$F = \frac{-2\mu^{1/2}}{c^2} = -4.442807633 (10)^{-10} \text{ sec}/(\text{meter})^{1/2},$$

where

$$\mu = 3.986005 \times 10^{14} \frac{\text{meters}^3}{\text{second}^2} = \text{value of Earth's universal gravitational parameters}$$

$$c = 2.99792458 \times 10^8 \frac{\text{meters}}{\text{second}} = \text{speed of light.}$$

Note that equations (1) and (2), as written, are coupled. While the coefficients a_{f0} , a_{f1} and a_{f2} are generated by using GPS time as indicated in equation (2), sensitivity of t_{sv} to t is negligible. This negligible sensitivity will allow the user to approximate t by t_{sv} in equation (2). The value of t must account for beginning or end of week crossovers. That is, if the quantity $t - t_{oc}$ is greater than 302,400 seconds, subtract 604,800 seconds from t . If the quantity $t - t_{oc}$ is less than -302,400 seconds, add 604,800 seconds to t .

The control segment will utilize the following alternative but equivalent expression for the relativistic effect when estimating the NAV parameters:

$$\Delta t_r = - \frac{2 \vec{R} \cdot \vec{V}}{c^2}$$

where

- \vec{R} is the instantaneous position vector of the SV,
- \vec{V} is the instantaneous velocity vector of the SV, and
- c is the speed of light. (Reference paragraph 20.3.4.3).

It is immaterial whether the vectors \vec{R} and \vec{V} are expressed in earth-fixed, rotating coordinates or in earth-centered, inertial coordinates.

20.3.3.3.3.2 L1 - L2 Correction. The L1 and L2 correction term, T_{GD} , is initially calculated by the CS to account for the effect of SV group delay differential between L1 P(Y) and L2 P(Y) based on measurements made by the SV contractor during SV manufacture. The value of T_{GD} for each SV may be subsequently updated to reflect the actual on-orbit group delay differential. This correction term is only for the benefit of "single-frequency" (L1 P(Y) or L2 P(Y)) users; it is necessitated by the fact that the SV clock offset estimates reflected in the a_{f_0} clock correction coefficient (see paragraph 20.3.3.3.3.1) are based on the effective PRN code phase as apparent with two frequency (L1 P(Y) and L2 P(Y)) ionospheric corrections. Thus, the user who utilizes the L1 P(Y) signal only shall modify the code phase offset in accordance with paragraph 20.3.3.3.3.1 with the equation

$$(\Delta t_{SV})_{L1P(Y)} = \Delta t_{SV} - T_{GD}$$

where T_{GD} is provided to the user as subframe 1 data. For the user who utilizes L2 P(Y) only, the code phase modification is given by

$$(\Delta t_{SV})_{L2P(Y)} = \Delta t_{SV} - \gamma T_{GD}$$

where, denoting the nominal center frequencies of L1 and L2 as f_{L1} and f_{L2} respectively,

$$\gamma = (f_{L1}/f_{L2})^2 = (1575.42/1227.6)^2 = (77/60)^2.$$

The value of T_{GD} is not equal to the mean SV group delay differential, but is a measured value that represents the mean group delay differential multiplied by $1/(1-\gamma)$. That is,

$$T_{GD} = \frac{1}{1-\gamma} (t_{L1P(Y)} - t_{L2P(Y)})$$

where $t_{L1P(Y)}$ is the GPS time the i^{th} frequency P(Y) signal is transmitted from the SV.

20.3.3.3.3.3 Ionospheric Correction. The two frequency (L1 P(Y) and L2 P(Y)) user shall correct for the group delay due to ionospheric effects by applying the relationship:

$$PR = \frac{PR_{L2P(Y)} - \gamma PR_{L1P(Y)}}{1 - \gamma}$$

where

- PR = pseudorange corrected for ionospheric effects,
- PR_i = pseudorange measured on the channel indicated by the subscript.

and γ is as defined in paragraph 20.3.3.3.3.2. The clock correction coefficients are based on "two frequency" measurements and therefore account for the effects of mean differential delay in SV instrumentation.

20.3.3.3.3.4 Example Application of Correction Parameters. A typical system application of the correction parameters for a user receiver is shown in Figure 20-3. The ionospheric model referred to in Figure 20-3 is discussed in paragraph 20.3.3.5.2.5 in conjunction with the related data contained in page 18 of subframe 4. The $\frac{ERD}{c}$ term referred to in Figure 20-3 is discussed in paragraph 20.3.3.5.2.6 in conjunction with the related data contained in page 13 of subframe 4.

20.3.3.4 Subframes 2 and 3. The contents of words three through ten of subframes 2 and 3 are defined below, followed by material pertinent to the use of the data.

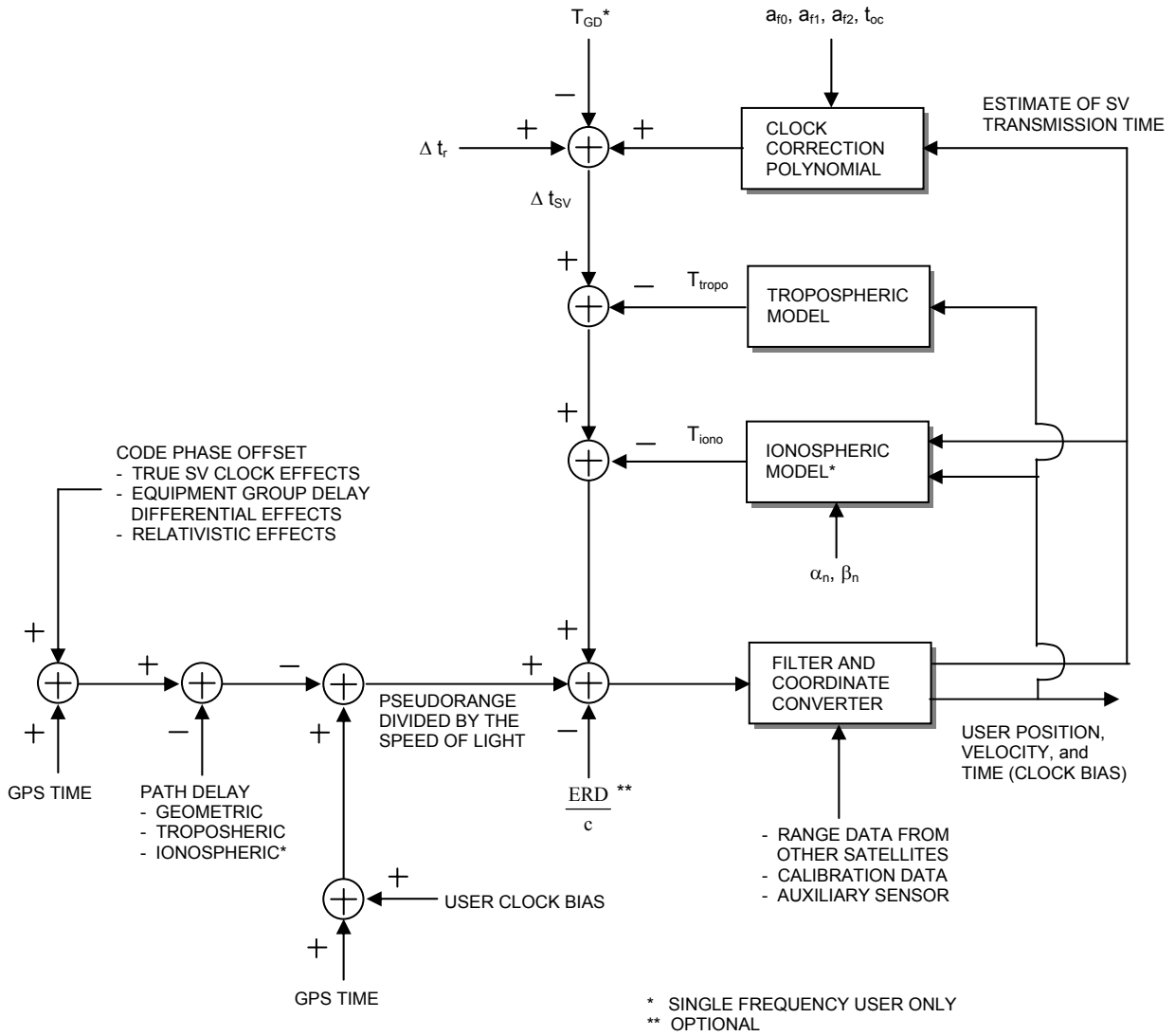

Figure 20-3. Sample Application of Correction Parameters

20.3.3.4.1 Content of Subframes 2 and 3. The third through tenth words of subframes 2 and 3 shall each contain six parity bits as their LSBs; in addition, two non-information bearing bits shall be provided as bits 23 and 24 of word ten of each subframe for parity computation purposes. Bits 288 through 292 of subframe 2 shall contain the Age of Data Offset (AODO) term for the navigation message correction table (NMCT) contained in subframe 4 (reference paragraph 20.3.3.5.1.12). The remaining 375 bits of those two subframes shall contain the ephemeris representation parameters of the transmitting SV.

The ephemeris parameters describe the orbit during the curve fit intervals described in section 20.3.4. Table 20-II gives the definition of the orbital parameters using terminology typical of Keplerian orbital parameters; it shall be noted, however, that the transmitted parameter values are such that they provide the best trajectory fit in Earth-Centered, Earth-Fixed (ECEF) coordinates for each specific fit interval. The user shall not interpret intermediate coordinate values as pertaining to any conventional coordinate system.

Table 20-II. Ephemeris Data Definitions

M_0	Mean Anomaly at Reference Time
Δn	Mean Motion Difference From Computed Value
e	Eccentricity
$(A)^{1/2}$	Square Root of the Semi-Major Axis
$(\text{OMEGA})_0$	Longitude of Ascending Node of Orbit Plane at Weekly Epoch
i_0	Inclination Angle at Reference Time
ω	Argument of Perigee
OMEGADOT	Rate of Right Ascension
IDOT	Rate of Inclination Angle
C_{uc}	Amplitude of the Cosine Harmonic Correction Term to the Argument of Latitude
C_{us}	Amplitude of the Sine Harmonic Correction Term to the Argument of Latitude
C_{rc}	Amplitude of the Cosine Harmonic Correction Term to the Orbit Radius
C_{rs}	Amplitude of the Sine Harmonic Correction Term to the Orbit Radius
C_{ic}	Amplitude of the Cosine Harmonic Correction Term to the Angle of Inclination
C_{is}	Amplitude of the Sine Harmonic Correction Term to the Angle of Inclination
t_{oe}	Reference Time Ephemeris (reference paragraph 20.3.4.5)
IODE	Issue of Data (Ephemeris)

The issue of ephemeris data (IODE) term shall provide the user with a convenient means for detecting any change in the ephemeris representation parameters. The IODE is provided in both subframes 2 and 3 for the purpose of comparison with the 8 LSBs of the IODC term in subframe 1. Whenever these three terms do not match, a data set cutover has occurred and new data must be collected. The timing of the IODE and constraints on the IODC and IODE are defined in paragraph 20.3.4.4.

Any change in the subframe 2 and 3 data will be accomplished with a simultaneous change in both IODE words. The CS shall assure that the t_{oc} value, for at least the first data set transmitted by an SV after an upload, is different from that transmitted prior to the cutover.

A "fit interval" flag is provided in subframe 2 to indicate whether the ephemerides are based on a four-hour fit interval or a fit interval greater than four hours (reference paragraph 20.3.3.4.3.1).

The AODO word is provided in subframe 2 to enable the user to determine the validity time for the NMCT data provided in subframe 4 of the transmitting SV. The related algorithm is given in paragraph 20.3.3.4.4.

20.3.3.4.2 Subframe 2 and 3 Parameter Characteristics. For each ephemeris parameter contained in subframes 2 and 3, the number of bits, the scale factor of the LSB (which shall be the last bit received), the range, and the units shall be as specified in Table 20-III.

The AODO word (which is not an ephemeris parameter) is a five-bit unsigned term with an LSB scale factor of 900, a range from 0 to 31, and units of seconds.

Table 20-III. Ephemeris Parameters				
Parameter	No. of Bits**	Scale Factor (LSB)	Effective Range***	Units
IODE	8			(see text)
C_{rs}	16*	2^{-5}		meters
Δn	16*	2^{-43}		semi-circles/sec
M_0	32*	2^{-31}		semi-circles
C_{uc}	16*	2^{-29}		radians
e	32	2^{-33}	0.03	dimensionless
C_{us}	16*	2^{-29}		radians
$(A)^{1/2}$	32	2^{-19}		meters ^{1/2}
t_{oe}	16	2^4	604,784	seconds
C_{ic}	16*	2^{-29}		radians
$(\text{OMEGA})_0$	32*	2^{-31}		semi-circles
C_{is}	16*	2^{-29}		radians
i_0	32*	2^{-31}		semi-circles
C_{rc}	16*	2^{-5}		meters
ω	32*	2^{-31}		semi-circles
OMEGADOT	24*	2^{-43}		semi-circles/sec
IDOT	14*	2^{-43}		semi-circles/sec
<p>* Parameters so indicated shall be two's complement, with the sign bit (+ or -) occupying the MSB; ** See Figure 20-1 for complete bit allocation in subframe; *** Unless otherwise indicated in this column, effective range is the maximum range attainable with indicated bit allocation and scale factor.</p>				

20.3.3.4.3 User Algorithm for Ephemeris Determination. The user shall compute the ECEF coordinates of position for the phase center of the SVs' antennas utilizing a variation of the equations shown in Table 20-IV. Subframes 2 and 3 parameters are Keplerian in appearance; the values of these parameters, however, are produced by the CS via a least squares curve fit of the predicted ephemeris of the phase center of the SVs' antennas (time-position quadruples; t, x, y, z expressed in ECEF coordinates). Particulars concerning the periods of the curve fit, the resultant accuracy, and the applicable coordinate system are given in the following subparagraphs.

20.3.3.4.3.1 Curve Fit Intervals. Bit 17 in word 10 of subframe 2 is a "fit interval" flag which indicates the curve-fit interval used by the CS in determining the ephemeris parameters, as follows:

0 = 4 hours,

1 = greater than 4 hours.

The relationship of the curve-fit interval to transmission time and the timing of the curve-fit intervals is covered in section 20.3.4.

Table 20-IV. Elements of Coordinate Systems (sheet 1 of 3)

$\mu = 3.986005 \times 10^{14} \text{ meters}^3/\text{sec}^2$	WGS 84 value of the earth's universal gravitational parameter for GPS user
$\dot{\Omega}_e = 7.2921151467 \times 10^{-5} \text{ rad/sec}$	WGS 84 value of the earth's rotation rate
$A = (\sqrt{A})^2$	Semi-major axis
$n_0 = \sqrt{\frac{\mu}{A^3}}$	Computed mean motion (rad/sec)
$t_k = t - t_{oc}^*$	Time from ephemeris reference epoch
$n = n_0 + \Delta n$	Corrected mean motion
$M_k = M_0 + nt_k$	Mean anomaly
<p>* t is GPS system time at time of transmission, i.e., GPS time corrected for transit time (range/speed of light). Furthermore, t_k shall be the actual total time difference between the time t and the epoch time t_{oc}, and must account for beginning or end of week crossovers. That is, if t_k is greater than 302,400 seconds, subtract 604,800 seconds from t_k. If t_k is less than -302,400 seconds, add 604,800 seconds to t_k.</p>	

Table 20-IV. Elements of Coordinate Systems (sheet 2 of 3)

$M_k = E_k - e \sin E_k$		Kepler's Equation for Eccentric Anomaly (may be solved by iteration)(radians)
$v_k = \tan^{-1} \left\{ \frac{\sin v_k}{\cos v_k} \right\}$		True Anomaly
$= \tan^{-1} \left\{ \frac{\sqrt{1-e^2} \sin E_k / (1 - e \cos E_k)}{(\cos E_k - e) / (1 - e \cos E_k)} \right\}$		
$E_k = \cos^{-1} \left\{ \frac{e + \cos v_k}{1 + e \cos v_k} \right\}$		Eccentric Anomaly
$\Phi_k = v_k + \omega$		Argument of Latitude
$\delta u_k = c_{us} \sin 2\Phi_k + c_{uc} \cos 2\Phi_k$	Argument of Latitude Correction Radius Correction Inclination Correction	} Second Harmonic Perturbations
$\delta r_k = c_{rs} \sin 2\Phi_k + c_{rc} \cos 2\Phi_k$		
$\delta i_k = c_{is} \sin 2\Phi_k + c_{ic} \cos 2\Phi_k$		
$u_k = \Phi_k + \delta u_k$		Corrected Argument of Latitude
$r_k = A(1 - e \cos E_k) + \delta r_k$		Corrected Radius
$i_k = i_0 + \delta i_k + (\text{IDOT}) t_k$		Corrected Inclination

Table 20-IV. Elements of Coordinate Systems (sheet 3 of 3)

$$\left. \begin{aligned} x_k' &= r_k \cos u_k \\ y_k' &= r_k \sin u_k \end{aligned} \right\}$$

Positions in orbital plane.

$$\Omega_k = \Omega_0 + (\dot{\Omega} - \dot{\Omega}_e) t_k - \dot{\Omega}_e t_{oe}$$

Corrected longitude of ascending node.

$$\left. \begin{aligned} x_k &= x_k' \cos \Omega_k - y_k' \cos i_k \sin \Omega_k \\ y_k &= x_k' \sin \Omega_k + y_k' \cos i_k \cos \Omega_k \\ z_k &= y_k' \sin i_k \end{aligned} \right\}$$

Earth-fixed coordinates.

20.3.3.4.3.2 Parameter Sensitivity. The sensitivity of the SV's antenna phase center position to small perturbations in most ephemeris parameters is extreme. The sensitivity of position to the parameters $(A)^{1/2}$, C_{rc} and C_{rs} is about one meter/meter. The sensitivity of position to the angular parameters is on the order of 10^8 meters/semicircle, and to the angular rate parameters is on the order of 10^{12} meters/semicircle/second. Because of this extreme sensitivity to angular perturbations, the value of π used in the curve fit is given here. π is a mathematical constant, the ratio of a circle's circumference to its diameter. Here π is taken as

$$\pi = 3.1415926535898.$$

20.3.3.4.3.3 Coordinate Systems.

20.3.3.4.3.3.1 ECEF Coordinate System. The equations given in Table 20-IV provide the SV's antenna phase center position in the WGS 84 ECEF coordinate system defined as follows:

- Origin* = Earth's center of mass
- Z-Axis** = The direction of the IERS (International Earth Rotation Service) Reference Pole (IRP)
- X-Axis = Intersection of the IERS Reference Meridian (IRM) and the plane passing through the origin and normal to the Z-axis
- Y-Axis = Completes a right-handed, Earth-Centered, Earth-Fixed orthogonal coordinate system

* Geometric center of the WGS 84 Ellipsoid

** Rotational axis of the WGS 84 Ellipsoid

20.3.3.4.3.3.2 Earth-Centered, Inertial (ECI) Coordinate System. In an ECI coordinate system, GPS signals propagate in straight lines at the constant speed c^* (reference paragraph 20.3.4.3). A stable ECI coordinate system of convenience may be defined as being coincident with the ECEF coordinate system at a given time t_0 . The x, y, z coordinates in the ECEF coordinate system at some other time t can be transformed to the x', y', z' coordinates in the selected ECI coordinate system of convenience by the simple** rotation:

$$x' = x \cos(\theta) - y \sin(\theta)$$

$$y' = x \sin(\theta) + y \cos(\theta)$$

$$z' = z$$

where

$$\theta = \dot{\Omega}_e (t - t_0)$$

* The propagation speed c is constant only in a vacuum. The gravitational potential also has a small effect on the propagation speed, but may be neglected by most users.

** Neglecting effects due to polar motion, nutation, and precession which may be neglected by most users for small values of $(t - t_0)$.

20.3.3.4.3.4 Geometric Range. The user shall account for the geometric range (D) from satellite to receiver in an ECI coordinate system. D may be expressed as,

$$D = | \vec{r}(t_R) - \vec{R}(t_T) |$$

where

t_T and t_R are the GPS system times of transmission and reception, respectively,

and where,

$\vec{R}(t_T)$ = position vector of the GPS satellite in the selected ECI coordinate system at time t_T ,

$\vec{r}(t_R)$ = position vector of the receiver in the selected ECI coordinate system at time t_R .

UNCLASSIFIED

20.3.3.4.4 NMCT Validity Time. Users desiring to take advantage of the NMCT data provided in page 13 of subframe 4 shall first examine the AODO term currently provided in subframe 2 of the NAV data from the transmitting SV. If the AODO term is 27900 seconds (i.e., binary 11111), then the NMCT currently available from the transmitting SV is invalid and shall not be used. If the AODO term is less than 27900 seconds, then the user shall compute the validity time for that NMCT (t_{nmct}) using the ephemeris t_{oe} parameter and the AODO term from the current subframe 2 as follows:

$$\text{OFFSET} = t_{oe} \text{ [Modulo 7200]}$$

$$\text{if } \text{OFFSET} = 0, \text{ then } t_{nmct} = t_{oe} - \text{AODO}$$

$$\text{if } \text{OFFSET} > 0, \text{ then } t_{nmct} = t_{oe} - \text{OFFSET} + 7200 - \text{AODO}$$

Note that the foregoing computation of t_{nmct} must account for any beginning or end of week crossovers; for example,

$$\text{if } t^* - t_{nmct} > 302,400 \text{ then } t_{nmct} = t_{nmct} + 604,800$$

$$\text{if } t^* - t_{nmct} < -302,400 \text{ then } t_{nmct} = t_{nmct} - 604,800$$

* t is GPS system time at time of transmission.

Users are advised that different SVs will transmit NMCTs with different t_{nmct} and that the best performance will generally be obtained by applying data from the NMCT with the latest (largest) t_{nmct} . As a result, users should compute and examine the t_{nmct} values for all visible and available SVs in order to find and use the NMCT with the latest t_{nmct} . If the same latest (largest) t_{nmct} is provided by two or more visible and available SVs, then the NMCT from any SV with the latest t_{nmct} may be selected and used; however, the estimated range deviation (ERD) value provided by the selected NMCT for the other SVs with the same t_{nmct} shall be set to zero if those SVs are used in the positioning solution. It should be noted that the intended positioning solution accuracy improvement will not be obtained if the data from two different NMCTs are applied simultaneously or if the data from a given NMCT is applied to just a subset of the SVs used in the positioning solution (i.e., mixed mode operation results in potentially degraded solution accuracy).

It should be noted that the NMCT information shall be supported by the Block IIR SV only when operating in the IIA like mode of operation including the Autonav Test mode.

**IRN-200C-003
ICD-GPS-200C
11 OCT 1999**

UNCLASSIFIED

20.3.3.5 Subframes 4 and 5. Both subframe 4 and 5 are subcommutated 25 times each; the 25 versions of these subframes are referred to as pages 1 through 25 of each subframe. With the possible exception of "reserved for system use" pages and explicit repeats, each page contains different specific data in words three through ten. As shown in Figure 20-1, the pages of subframe 4 utilize seven different formats, while those of subframe 5 use two. The content of words three through ten of each page is described below, followed by algorithms and material pertinent to the use of the data.

20.3.3.5.1 Content of Subframes 4 and 5. Words three through ten of each page contain six parity bits as their LSBs; in addition, two non-information bearing bits are provided as bits 23 and 24 of word ten in each page for parity computation purposes. The data contained in the remaining bits of words three through ten of the various pages in subframes 4 and 5 are described in the following subparagraphs.

IRN-200C-003
ICD-GPS-200C
11 OCT 1999

UNCLASSIFIED

A brief summary of the various data contained in each page of subframes 4 and 5 is as follows:

a. Subframe 4:

- Pages 1, 6, 11, 16 and 21: (reserved);
- Pages 2, 3, 4, 5, 7, 8, 9 and 10: almanac data for SV 25 through 32 respectively. These pages may be designated for other functions; the format and content for each page is defined by the SV ID of that page. In this case, the six-bit health word of page 25 is set to "6 ones" (Refer to 20.3.3.5.1.3) and the SV ID of the page will not have a value in the range of 25 through 32;
- Pages 12, 19, 20, 22, 23 and 24: (reserved);
- Page 13: NMCT;
- Pages 14 and 15: reserved for system use;
- Page 17: special messages;
- Page 18: ionospheric and UTC data;
- Page 25: A-S flags/SV configurations for 32 SVs, plus SV health for SV 25 through 32.

b. Subframe 5:

- Pages 1 through 24: almanac data for SV 1 through 24;
- Page 25: SV health data for SV 1 through 24, the almanac reference time, the almanac reference week number, and the calendar year counter (for Block IIF).

IRN-200C-005R1
ICD-GPS-200C
14 Jan 2003

20.3.3.5.1.1 Data ID and SV ID. The two MSBs of word three in each page shall contain data ID. Data ID number two (denoted by binary code 01) denotes the NAV data structure of D(t) which is described in this Appendix. Future data IDs will be defined as necessary.

As shown in Table 20-V, the data ID is utilized to provide one of two indications: (a) for those pages which are assigned to contain the almanac data of one specific SV, the data ID defines the data structure utilized by that SV whose almanac data are contained in that page; and (b) for all other pages, the data ID denotes the data structure of the transmitting SV.

The SV ID is given by bits three through eight of word three in each page as shown in Table 20-V. Specific IDs are reserved for each page of subframes 4 and 5; however, the SV ID of pages 2, 3, 4, 5, 7, 8, 9 and 10 of subframe 4 may change for each page to reflect the alternate contents for that page. The SV IDs are utilized in two different ways: (a) for those pages which contain the almanac data of a given SV, the SV ID is the same number that is assigned to the PRN code phase of that SV (reference Table 3-I), and (b) for all other pages the SV ID assigned in accordance with Table 20-V serves as the "page ID". IDs 1 through 32 are assigned to those pages which contain the almanac data of specific SVs (pages 1-24 of subframe 5 and pages 2-5 and 7-10 of subframe 4). The "0" ID (binary all zeros) is assigned to indicate a dummy SV, while IDs 51 through 63 are utilized for pages containing other than almanac data of a specific SV. The remaining IDs (33 through 50) are unassigned.

Pages which carry the same SV ID (e.g., in subframe 4, pages 1, 6, 11, 16 and 21 carry an ID of 57, while pages 12 and 24 are designated by an ID of 62) may not be considered to contain identical data. The data in the pages with the same SV ID can be different.

UNCLASSIFIED

Table 20-V. Data IDs and SV IDs in Subframes 4 and 5

Page	Subframe 4		Subframe 5	
	Data ID	SV ID*	Data ID	SV ID*
1	Note(2)	57	Note(1)	1
2 Note(3)	Note(1)	25	Note(1)	2
3 Note(3)	Note(1)	26	Note(1)	3
4 Note(3)	Note(1)	27	Note(1)	4
5 Note(3)	Note(1)	28	Note(1)	5
6	Note(2)	57	Note(1)	6
7 Note(3)	Note(1)	29	Note(1)	7
8 Note(3)	Note(1)	30	Note(1)	8
9 Note(3)	Note(1)	31	Note(1)	9
10 Note(3)	Note(1)	32	Note(1)	10
11	Note(2)	57	Note(1)	11
12	Note(2)	62	Note(1)	12
13	Note(2)	52	Note(1)	13
14	Note(2)	53	Note(1)	14
15	Note(2)	54	Note(1)	15
16	Note(2)	57	Note(1)	16
17	Note(2)	55	Note(1)	17
18	Note(2)	56	Note(1)	18
19	Note(2)	58 Note(4)	Note(1)	19
20	Note(2)	59 Note(4)	Note(1)	20
21	Note(2)	57	Note(1)	21
22	Note(2)	60 Note(4)	Note(1)	22
23	Note(2)	61 Note(4)	Note(1)	23
24	Note(2)	62	Note(1)	24
25	Note(2)	63	Note(2)	51

* Use "0" to indicate "dummy" SV. When using "0" to indicate dummy SV, use the data ID of the transmitting SV.

Note 1: Data ID of that SV whose SV ID appears in that page.
 Note 2: Data ID of transmitting SV.
 Note 3: Pages 2, 3, 4, 5, 7, 8, 9, and 10 of subframe 4 may contain almanac data for SVs 25 through 32, respectively, or data for other functions as identified by a different SV ID from the value shown.
 Note 4: SV ID may vary.

20.3.3.5.1.2 Almanac Data. Pages 1 through 24 of subframe 5, as well as pages 2 through 5 and 7 through 10 of subframe 4 contain the almanac data and a SV health word for up to 32 SVs (the health word is discussed in paragraph 20.3.3.5.1.3). The almanac data are a reduced-precision subset of the clock and ephemeris parameters. The data occupy all bits of words three through ten of each page except the eight MSBs of word three (data ID and SV ID), bits 17 through 24 of word five (SV health), and the 50 bits devoted to parity. The number of bits, the scale factor (LSB), the range, and the units of the almanac parameters are given in Table 20-VI. The algorithms and other material related to the use of the almanac data are given in paragraph 20.3.3.5.2.

The almanac message for any dummy SVs shall contain alternating ones and zeros with valid parity. For twelve or fewer SVs, almanacs may be repeated within the 25-cycle subcommutation limit. Whenever this option is exercised, the following constraints shall apply: (a) each page of subframes 4 and 5, which is assigned by Table 20-V to one of the active SVs in orbit, must contain the almanac data of that SV to which it is assigned by Table 20-V, (b) those almanac-type pages which remain unused per the above rule, shall then be re-assigned to carry a duplicate set of almanac data for the active orbiting SV, (c) these page re-assignments shall be in ascending order of page numbers (starting with subframe 5, followed by subframe 4) being used for SVs having an ascending order of SV IDs, and (d) each re-assigned page must carry the SV ID of that SV whose almanac data it contains.

The almanac parameters shall be updated by the CS at least once every 6 days while the CS is able to upload the SVs. If the CS is unable to upload the SVs, the accuracy of the almanac parameters transmitted by the SVs will degrade over time.

UNCLASSIFIED

For Block II and IIA SVs, three sets of almanac shall be used to span 182 days. The first and second sets will be transmitted for up to six days each; the third set is intended to be transmitted for the duration of the 182 days from the last upload, but the duration of transmission will depend on the individual SV's capability to retain data in memory. All three sets are based on six-day curve fits that correspond to the first six days of the transmission interval. For Block IIR/IIR-M and IIF SVs, multiple sets of almanac parameters shall be uploaded to span 210 days and 90 days, respectively.

IRN-200C-005R1
ICD-GPS-200C
14 Jan 2003

UNCLASSIFIED

Table 20-VI. Almanac Parameters				
Parameter	No. of Bits**	Scale Factor (LSB)	Effective Range***	Units
e	16	2^{-21}	602,112	dimensionless
t_{oa}	8	2^{12}		seconds
δ_i ****	16*	2^{-19}		semi-circles
OMEGADOT	16*	2^{-38}		semi-circles/sec
$(A)^{1/2}$	24	2^{-11}		meters ^{1/2}
$(\text{OMEGA})_0$	24*	2^{-23}		semi-circles
ω	24*	2^{-23}		semi-circles
M_0	24*	2^{-23}		semi-circles
a_{f0}	11*	2^{-20}		seconds
a_{f1}	11*	2^{-38}		sec/sec
<p>* Parameters so indicated shall be two's complement with the sign bit (+ or -) occupying the MSB;</p> <p>** See Figure 20-1 for complete bit allocation in subframe;</p> <p>*** Unless otherwise indicated in this column, effective range is the maximum range attainable with indicated bit allocation and scale factor;</p> <p>**** Relative to $i_0 = 0.30$ semi-circles.</p>				

20.3.3.5.1.3 SV Health. Subframes 4 and 5 contain two types of SV health data: (a) each of the 32 pages which contain the clock/ephemeris related almanac data provide an eight-bit SV health status word regarding the SV whose almanac data they carry, and (b) the 25th page of subframe 4 and of subframe 5 jointly contain six-bit health status data for up to 32 SVs.

The three MSBs of the eight-bit health words indicate health of the NAV data in accordance with the code given in Table 20-VII. The six-bit words provide a one-bit summary of the NAV data's health status in the MSB position in accordance with paragraph 20.3.3.3.1.4. The five LSBs of both the eight-bit and the six-bit words provide the health status of the SV's signal components in accordance with the code given in Table 20-VIII. A special meaning is assigned, however, to the "6 ones" combination of the six-bit health words in the 25th page of subframes 4 and 5: it indicates that "the SV which has that ID is not available and there may be no data regarding that SV in that page of subframes 4 and 5 that is assigned to normally contain the almanac data of that SV" (NOTE: (a) this special meaning applies to the 25th page of subframes 4 and 5 only; and (b) there may be data regarding another SV in the almanac-page referred to above as defined in paragraph 20.3.3.5.1.1). The health indication shall be given relative to the "as designed" capabilities of each SV (as designated by the configuration code -- see paragraph 20.3.3.5.1.6). Accordingly, any SV which does not have a certain capability will be indicated as "healthy" if the lack of this capability is inherent in its design or it has been configured into a mode which is normal from a user standpoint and does not require that capability.

Table 20-VII. NAV Data Health Indications			
Bit Position in Page			Indication
137	138	139	
0	0	0	ALL DATA OK
0	0	1	PARITY FAILURE -- some or all parity bad
0	1	0	TLM/HOW FORMAT PROBLEM -- any departure from standard format (e.g., preamble misplaced and/or incorrect, etc.), except for incorrect Z-count, as reported in HOW
0	1	1	Z-COUNT IN HOW BAD -- any problem with Z-count value not reflecting actual code phase
1	0	0	SUBFRAMES 1, 2, 3 -- one or more elements in words three through ten of one or more subframes are bad
1	0	1	SUBFRAMES 4, 5 -- one or more elements in words three through ten of one or more subframes are bad
1	1	0	ALL UPLOADED DATA BAD -- one or more elements in words three through ten of any one (or more) subframes are bad
1	1	1	ALL DATA BAD -- TLM word and/or HOW and one or more elements in any one (or more) subframes are bad

MSB		LSB	Definition
0	0	0	All Signals OK
0	0	0	All Signals Weak*
0	0	0	All Signals Dead
0	0	0	All Signals Have No Data Modulation
0	0	1	L1 P Signal Weak
0	0	1	L1 P Signal Dead
0	0	1	L1 P Signal Has No Data Modulation
0	0	1	L2 P Signal Weak
0	1	0	L2 P Signal Dead
0	1	0	L2 P Signal Has No Data Modulation
0	1	0	L1 C Signal Weak
0	1	0	L1 C Signal Dead
0	1	0	L1 C Signal Has No Data Modulation
0	1	0	L2 C Signal Weak
0	1	0	L2 C Signal Dead
0	1	0	L2 C Signal Has No Data Modulation
1	0	0	L1 & L2 P Signal Weak
1	0	0	L1 & L2 P Signal Dead
1	0	0	L1 & L2 P Signal Has No Data Modulation
1	0	0	L1 & L2 C Signal Weak
1	0	0	L1 & L2 C Signal Dead
1	0	0	L1 & L2 C Signal Has No Data Modulation
1	0	1	L1 Signal Weak*
1	0	1	L1 Signal Dead
1	0	1	L1 Signal Has No Data Modulation
1	1	0	L2 Signal Weak*
1	1	0	L2 Signal Dead
1	1	0	L2 Signal Has No Data Modulation
1	1	0	SV <u>Is</u> Temporarily Out (Do not use this SV during current pass)**
1	1	0	SV <u>Will Be</u> Temporarily Out (Use with caution)**
1	1	1	Spare
1	1	1	More Than One Combination Would Be Required To Describe Anomalies (Not including those marked with “**”))

* 3 to 6 dB below specified power level due to reduced power output, excess phase noise, SV attitude, etc.
 ** See definition above for Health Code 11111.

Additional SV health data are given in subframe 1. The data given in subframes 1, 4, and 5 of the other SVs may differ from that shown in subframes 4 and/or 5 since the latter may be updated at a different time.

The eight-bit health status words shall occupy bits 17 through 24 of word five in those 32 pages which contain almanac data for individual SVs. The six-bit health status words shall occupy the 24 MSBs of words four through nine in page 25 of subframe 5 plus bits 19 through 24 of word 8, the 24 MSBs of word 9, and the 18 MSBs of word 10 in page 25 of subframe 4.

The predicted health data will be updated at the time of upload when a new almanac has been built by the CS. The transmitted health data may not correspond to the actual health of the transmitting SV or other SVs in the constellation.

20.3.3.5.1.4 (Reserved).

20.3.3.5.1.5 (Reserved).

20.3.3.5.1.6 Anti-Spoof (A-S) Flags and SV Configurations. Page 25 of subframe 4 shall contain a four-bit-long term for each of up to 32 SVs to indicate the A-S status and the configuration code of each SV. The MSB of each four-bit term shall be the A-S flag with a "1" indicating that A-S is ON. The three LSBs shall indicate the configuration of each SV using the following code:

<u>Code</u>	<u>SV Configuration</u>
001	“Block II/IIA/IIR” SV (A-S capability, plus flags for A-S and "alert" in HOW; memory capacity as described in paragraph 20.3.2).
010	“Block IIR-M” SV
011	“Block IIF” SV

Additional codes will be assigned in the future, should the need arise.

These four-bit terms shall occupy bits 9 through 24 of word three, the 24 MSBs of words four through seven, and the 16 MSBs of word eight, all in page 25 of subframe 4.

Since the anti-spoof information is updated by the CS at the time of upload, the anti-spoof data may not correspond to the actual anti-spoof status of the transmitting SV or other SVs in the constellation.

20.3.3.5.1.7 Almanac Reference Week. Bits 17 through 24 of word three in page 25 of subframe 5 shall indicate the number of the week (WN_a) to which the almanac reference time (t_{oa}) is referenced (see paragraphs 20.3.3.5.1.2 and 20.3.3.5.2.2). The WN_a term consists of eight bits which shall be a Modulo 256 binary representation of the GPS week number (see paragraph 6.2.4) to which the t_{oa} is referenced. Bits 9 through 16 of word three in page 25 of subframe 5 shall contain the value of t_{oa} which is referenced to this WN_a .

20.3.3.5.1.8 Universal Coordinated Time (UTC) Parameters. The 24 MSBs of words six through nine plus the eight MSBs of word ten in page 18 of subframe 4 shall contain the parameters related to correlating UTC time with GPS time. The bit length, scale factors, ranges, and units of these parameters are given in Table 20-IX. The related algorithms are described in paragraph 20.3.3.5.2.4.

UNCLASSIFIED

The UTC parameters shall be updated by the CS at least once every six days while the CS is able to upload the SVs. If the CS is unable to upload the SVs, the accuracy of the UTC parameters transmitted by the SVs will degrade over time.

20.3.3.5.1.9 Ionospheric Data. The ionospheric parameters which allow the "L1 only" or "L2 only" user to utilize the ionospheric model (reference paragraph 20.3.3.5.2.5) for computation of the ionospheric delay are contained in page 18 of subframe 4. They occupy bits 9 through 24 of word three plus the 24 MSBs of words four and five. The bit lengths, scale factors, ranges, and units of these parameters are given in Table 20-X.

The ionospheric data shall be updated by the CS at least once every six days while the CS is able to upload the SVs. If the CS is unable to upload the SVs, the ionospheric data transmitted by the SVs may not be accurate.

ICD-GPS-200C
10 OCT 1993

Table 20-IX. UTC Parameters				
Parameter	No. of Bits**	Scale Factor (LSB)	Effective Range***	Units
A ₀	32*	2 ⁻³⁰	602,112	Seconds
A ₁	24*	2 ⁻⁵⁰		sec/sec
Δ t _{LS}	8*	1		seconds
t _{ot}	8	2 ¹²		seconds
WN _t	8	1		weeks
WN _{LSF}	8	1		weeks
DN	8****	1		7
Δ t _{LSF}	8*	1		seconds

* Parameters so indicated shall be two's complement with the sign bit (+ or -) occupying the MSB;

** See Figure 20-1 for complete bit allocation in subframe;

*** Unless otherwise indicated in this column, effective range is the maximum range attainable with indicated bit allocation and scale factor;

**** Right justified.

Table 20-X. Ionospheric Parameters				
Parameter	No. of Bits**	Scale Factor (LSB)	Effective Range***	Units
α_0	8*	2^{-30}		Seconds
α_1	8*	2^{-27}		sec/semi-circle
α_2	8*	2^{-24}		sec/(semi-circle) ²
α_3	8*	2^{-24}		sec/(semi-circle) ³
β_0	8*	2^{11}		seconds
β_1	8*	2^{14}		sec/semi-circle
β_2	8*	2^{16}		sec/(semi-circle) ²
β_3	8*	2^{16}		sec/(semi-circle) ³
<p>* Parameters so indicated shall be two's complement with the sign bit (+ or -) occupying the MSB;</p> <p>** See Figure 20-1 for complete bit allocation in subframe;</p> <p>*** Unless otherwise indicated in this column, effective range is the maximum range attainable with indicated bit allocation and scale factor.</p>				

UNCLASSIFIED

20.3.3.5.1.10 Special Messages. Page 17 of subframe 4 shall be reserved for special messages with the specific contents at the discretion of the Operating Command. It shall accommodate the transmission of 22 eight-bit ASCII characters. The requisite 176 bits shall occupy bits 9 through 24 of word three, the 24 MSBs of words four through nine, plus the 16 MSBs of word ten. The eight MSBs of word three shall contain the data ID and SV ID, while bits 17 through 22 of word ten shall be reserved for system use. The remaining 50 bits of words three through ten are used for parity (six bits/word) and parity computation (two bits in word ten). The eight-bit ASCII characters shall be limited to the following set:

<u>Alphanumeric Character</u>	<u>ASCII Character</u>	<u>Code (Octal)</u>
A - Z	A - Z	101 - 132
0 - 9	0 - 9	060 - 071
+	+	053
-	-	055
. (Decimal point)	.	056
' (Minute mark)	'	047
° (Degree sign)	°	370
/	/	057
Blank	Space	040
:	:	072
" (Second mark)	"	042

IRN-200C-002
ICD-GPS-200C
25 SEP 1997

20.3.3.5.1.11 (Deleted)

20.3.3.5.1.12 NMCT. Page 13 of subframe 4 shall contain the NMCT data appropriate to the transmitting SV. Each NMCT contains a two-bit availability indicator (AI) followed by 30 slots which may contain up to 30 valid six-bit ERD values. The layout of these 31 data items is as shown in Figure 20-1.

The two-bit AI in bits 9 and 10 of word three of page 13 of subframe 4 provide the user with the following information.

<u>AI</u>	<u>Navigation Message Correction Table Availability</u>
00	The correction table is unencrypted and is available to both authorized and unauthorized users.
01	The correction table is encrypted and is available only to authorized users (normal mode).
10	No correction table available for either authorized or unauthorized users.
11	Reserved.

Each one of the 30 six-bit ERD slots in bits 11 through 24 of word three, bits 1 through 24 of words four through nine, and bits 1 through 22 of word ten of page 13 of subframe 4 will correspond to an ERD value for a particular SV ID. There are 31 possible SV IDs that these ERD slots may correspond to, ranging from SV ID 1 to SV ID 31. SV ID 32 is not a valid SV ID for any of the slots in an NMCT. The correspondence between the 30 ERD slots and the 31 possible SV IDs depends on the SV ID of the particular transmitting SV in accordance with the following two rules: 1) the CS shall ensure via upload that no SV shall transmit an NMCT containing an ERD value which applies to its own SV ID, and 2) the CS shall ensure via upload that all ERD values shall be transmitted in ascending numerical slot order of the corresponding SV ID. To illustrate: the SV operating as SV ID 1 will transmit (in order) ERD values which correspond to SV ID 2 through SV ID 31 in ERD slots 1 through 30 respectively, while the SV operating as SV ID 31 will transmit ERD values which correspond to SV ID 1 through SV ID 30 in ERD slots 1 through 30 respectively.

Each ERD value contained in an NMCT ERD slot shall be represented as a six-bit two's complement field with the sign bit occupying the MSB and an LSB of 0.3 meters for an effective range of ± 9.3 m. A binary value of "100000" shall indicate that no valid ERD for the corresponding SV ID is present in that slot.

20.3.3.5.1.13 Calendar Year Counter. For Block IIF SVs, bits 7 through 22 of word ten in page 25 of subframe 5 shall indicate the calendar year (reference paragraph 6.2.5). The CS shall ensure that this counter shall increment at the start of the GPS day (reference paragraph 6.2.6) corresponding to calendar January 1st.

Note that for other blocks of SVs, bits 7 through 22 of word ten in pages 25 of subframe 5 do not provide calendar year counter. For these other blocks of SVs, the 16 bits nominally provide alternating ones and zeros.

20.3.3.5.2 Algorithms Related to Subframe 4 and 5 Data. The following algorithms shall apply when interpreting Almanac, Universal Coordinated Time, Ionospheric Model, and NMCT data in the NAV message.

20.3.3.5.2.1 Almanac. The almanac is a subset of the clock and ephemeris data, with reduced precision. The user algorithm is essentially the same as the user algorithm used for computing the precise ephemeris from the one subframe 1, 2, and 3 parameters (see Table 20-IV). The almanac content for one SV is given in Table 20-VI. A close inspection of Table 20-VI will reveal that a nominal inclination angle of 0.30 semicircles is implicit and that the parameter δ ; (correction to inclination) is transmitted, as opposed to the value computed by the user. All other parameters appearing in the equations of Tables 20-IV, but not included in the content of the almanac, are set to zero for SV position determination. In these respects, the application of the Table 20-IV equations differs between the almanac and the ephemeris computations.

UNCLASSIFIED

(This page intentionally left blank.)

**IRN-200C-002
ICD-GPS-200C
25 SEP 1997**

118b

UNCLASSIFIED

Table 20-XI. (Deleted)

**IRN-200C-002
ICD-GPS-200C
25 SEP 1997**

UNCLASSIFIED

The user is cautioned that the sensitivity to small perturbations in the parameters is even greater for the almanac than for the ephemeris, with the sensitivity of the angular rate terms over the interval of applicability on the order of 10^{14} meters/(semicircle/second). An indication of the URE provided by a given almanac during each of the operational intervals is as follows:

<u>Operational Interval</u>	Almanac Ephemeris URE (estimated by analysis) <u>1 sigma (meters)</u>
Normal	900* [†]
Short-term Extended	900 - 3,600*
Long-term Extended	3600 - 300,000*

* URE values generally tend to degrade quadratically over time. Larger errors may be encountered during eclipse seasons and whenever a propulsive event has occurred.

† After the CS is unable to upload the SVs, URE values for the SVs operating in the Autonav mode tend to degrade quadratically such that the URE will approach 300,000 meters 1 sigma at 180 days.

IRN-200C-005R1
ICD-GPS-200C
14 Jan 2003

20.3.3.5.2.2 Almanac Reference Time.

Normal and Short-term Extended Operations. The almanac reference time, t_{oa} , is some multiple of 2^{12} seconds occurring approximately 70 hours after the first valid transmission time for this almanac data set (reference 20.3.4.5). The almanac is updated often enough to ensure that GPS time, t , shall differ from t_{oa} by less than 3.5 days during the transmission period. The time from epoch t_k shall be computed as described in Table 20-IV, except that t_{oe} shall be replaced with t_{oa} .

Long-term Extended Operations. During long-term extended operations or if the user wishes to extend the use time of the almanac beyond the time span that it is being transmitted, one must account for crossovers into time spans where these computations of t_k are not valid. This may be accomplished without time ambiguity by recognizing that the almanac reference time (t_{oa}) is referenced to the almanac reference week (WN_a), both of which are given in word three of page 25 of subframe 5 (see paragraph 20.3.3.5.1.7).

All t_{oa} values in subframes 4 and 5 shall be the same for a given almanac data set and shall differ for successive data sets which contain changes in almanac parameters or SV health. Note that cutover to a new upload may occur between the almanac pages of interest and page 25 of subframe 5 (reference paragraph 20.3.4.1), and thus there may be a temporary inconsistency between t_{oa} , in the almanac page of interest, and in word 3 of page 25 of subframe 5. The t_{oa} mismatch signifies that this WN_a may not apply to the almanac of interest and that the user must not apply almanac data until the pages with identical values of t_{oa} are obtained.

20.3.3.5.2.3 Almanac Time Parameters. The almanac time parameters shall consist of an 11-bit constant term (a_{f0}) and an 11-bit first order term (a_{f1}). The applicable first order polynomial, which shall provide time to within 2 microseconds of GPS time (t) during the interval of applicability, is given by

$$t = t_{sv} - \Delta t_{sv}$$

where

$$\begin{aligned}
 t &= \text{GPS system time (seconds),} \\
 t_{sv} &= \text{effective SV PRN code phase time at message transmission time} \\
 &\quad \text{(seconds),} \\
 \Delta t_{sv} &= \text{SV PRN code phase time offset (seconds).}
 \end{aligned}$$

The SV PRN code phase offset is given by

$$\Delta t_{sv} = a_{f0} + a_{f1} t_k$$

where the computation of t_k is described in paragraph 20.3.3.5.2.2, and the polynomial coefficients a_{f0} and a_{f1} are given in the almanac. Since the periodic relativistic effect is less than 25 meters, it need not be included in the time scale used for almanac evaluation. Over the span of applicability, it is expected that the almanac time parameters will provide a statistical URE component of less than 135 meters, one sigma. This is partially due to the fact that the error caused by the truncation of a_{f0} and a_{f1} may be as large as 150 meters plus 50 meters/day relative to the t_{oa} reference time.

During extended operations (short-term and long-term) the almanac time parameter may not provide the specified time accuracy or URE component.

20.3.3.5.2.4 Universal Coordinated Time (UTC). Page 18 of subframe 4 includes: (1) the parameters needed to relate GPS time to UTC, and (2) notice to the user regarding the scheduled future or recent past (relative to NAV message upload) value of the delta time due to leap seconds (Δt_{LSF}), together with the week number (WN_{LSF}) and the day number (DN) at the end of which the leap second becomes effective. "Day one" is the first day relative to the end/start of week and the WN_{LSF} value consists of eight bits which shall be a Modulo 256 binary representation of the GPS week number (see paragraph 6.2.4) to which the DN is referenced. The user must account for the truncated nature of this parameter as well as truncation of WN , WN_t , and WN_{LSF} due to rollover of full week number (see paragraph 3.3.4(b)). The CS shall manage these parameters such that the absolute value of the difference between the untruncated WN and WN_{LSF} values shall not exceed 127.

Depending upon the relationship of the effectivity date to the user's current GPS time, the following three different UTC/GPS-time relationships exist:

a. Whenever the effectivity time indicated by the WN_{LSF} and the DN values is not in the past (relative to the user's present time), and the user's present time does not fall in the time span which starts at $DN + 3/4$ and ends at $DN + 5/4$, the UTC/GPS-time relationship is given by

$$t_{UTC} = (t_E - \Delta t_{UTC}) \text{ [Modulo 86400 seconds]}$$

where t_{UTC} is in seconds and

- Δt_{UTC} = $\Delta t_{LS} + A_0 + A_1 (t_E - t_{ot} + 604800 (WN - WN_t))$, seconds;
- t_E = GPS time as estimated by the user on the basis of correcting t_{SV} for factors described in paragraph 20.3.3.3.3 as well as for ionospheric and selective availability (SA) (dither) effects;
- Δt_{LS} = delta time due to leap seconds;
- A_0 and A_1 = constant and first order terms of polynomial;
- t_{ot} = reference time for UTC data (reference 20.3.4.5);
- WN = current week number (derived from subframe 1);
- WN_t = UTC reference week number.

The estimated GPS time (t_E) shall be in seconds relative to end/start of week. During the normal and short-term extended operations, the reference time for UTC data, t_{ot} , is some multiple of 2^{12} seconds occurring approximately 70 hours after the first valid transmission time for this UTC data set (reference 20.3.4.5). The reference time for UTC data (t_{ot}) shall be referenced to the start of that week whose number (WN_t) is given in word eight of page 18 in subframe 4. The WN_t value consists of eight bits which shall be a Modulo 256 binary representation of the GPS week number (see paragraph 6.2.4) to which the t_{ot} is referenced. The user must account for the truncated nature of this parameter as well as truncation of WN , WN_t , and WN_{LSF} due to rollover of full week number (see paragraph 3.3.4(b)). The CS shall manage these parameters such that the absolute value of the difference between the untruncated WN and WN_t values shall not exceed 127.

b. Whenever the user's current time falls within the time span of $DN + 3/4$ to $DN + 5/4$, proper accommodation of the leap second event with a possible week number transition is provided by the following expression for UTC:

$$t_{UTC} = W[\text{Modulo}(86400 + \Delta t_{LSF} - \Delta t_{LS})], \text{ seconds};$$

where

$$W = (t_E - \Delta t_{UTC} - 43200)[\text{Modulo } 86400] + 43200, \text{ seconds};$$

and the definition of Δt_{UTC} (as given in 20.3.3.5.2.4a above) applies throughout the transition period. Note that when a leap second is added, unconventional time values of the form 23:59:60.xxx are encountered. Some user equipment may be designed to approximate UTC by decrementing the running count of time within several seconds after the event, thereby promptly returning to a proper time indication. Whenever a leap second event is encountered, the user equipment must consistently implement carries or borrows into any year/week/day counts.

c. Whenever the effectivity time of the leap second event, as indicated by the WN_{LSF} and DN values, is in the "past" (relative to the user's current time), the relationship previously given for t_{UTC} in 20.3.3.5.2.4a above is valid except that the value of Δt_{LSF} is substituted for Δt_{LS} . The CS will coordinate the update of UTC parameters at a future upload so as to maintain a proper continuity of the t_{UTC} time scale.

20.3.3.5.2.5 Ionospheric Model. The "two frequency" (L1 and L2) user shall correct the time received from the SV for ionospheric effect by utilizing the time delay differential between L1 and L2 (reference paragraph 20.3.3.3.3.3). The "one frequency" user, however, may use the model given in Figure 20-4 to make this correction. It is estimated that the use of this model will provide at least a 50 percent reduction in the single - frequency user's RMS error due to ionospheric propagation effects. During extended operations, or for the SVs in the Autonav mode if the CS is unable to upload the SVs, the use of this model will yield unpredictable results.

20.3.3.5.2.6 NMCT Data. For each SV, the ERD value in the NMCT is an estimated pseudorange error. Each ERD value is computed by the CS and represents the radial component of the satellite ephemeris error minus the speed of light times the satellite clock error. The satellite ephemeris and clock errors are computed by subtracting the broadcast from current estimates. Therefore, the ERD value may be used as follows to correct the user's measured pseudorange:

$$PR_c = PR - ERD$$

where,

PR_c = pseudorange corrected with the ERD value from the NMCT

PR = measured pseudorange

Note that as described above, the ERD values are actually error estimates rather than differential corrections and so are subtracted rather than added in the above equation.

The ionospheric correction model is given by

$$T_{\text{iono}} = \begin{cases} F * \left[5.0 * 10^{-9} + (\text{AMP}) \left(1 - \frac{x^2}{2} + \frac{x^4}{24} \right) \right], & |x| < 1.57 \\ F * (5.0 * 10^{-9}) & , |x| \geq 1.57 \end{cases} \quad (\text{sec})$$

where

T_{iono} is referred to the L1 frequency; if the user is operating on the L2 frequency, the correction term must be multiplied by γ (reference paragraph 20.3.3.3.2),

$$\text{AMP} = \begin{cases} \sum_{n=0}^3 \alpha_n \phi_m^n, & \text{AMP} \geq 0 \\ \text{if AMP} < 0, & \text{AMP} = 0 \end{cases} \quad (\text{sec})$$

$$x = \frac{2\pi (t - 50400)}{\text{PER}} \quad (\text{radians})$$

$$\text{PER} = \begin{cases} \sum_{n=0}^3 \beta_n \phi_m^n, & \text{PER} \geq 72,000 \\ \text{if PER} < 72,000, & \text{PER} = 72,000 \end{cases} \quad (\text{sec})$$

$$F = 1.0 + 16.0 [0.53 - E]^3$$

and α_n and β_n are the satellite transmitted data words with $n = 0, 1, 2,$ and 3 .

Figure 20-4. Ionospheric Model (Sheet 1 of 3)

Other equations that must be solved are

$$\phi_m = \phi_i + 0.064 \cos(\lambda_i - 1.617) \quad (\text{semi-circles})$$

$$\lambda_i = \lambda_u + \frac{\psi \sin A}{\cos \phi_i} \quad (\text{semi-circles})$$

$$\phi_i = \left\{ \begin{array}{l} \phi_u + \psi \cos A (\text{semi-circles}), |\phi_i| \leq 0.416 \\ \text{if } \phi_i > +0.416, \text{ then } \phi_i = +0.416 \\ \text{if } \phi_i < -0.416, \text{ then } \phi_i = -0.416 \end{array} \right\} \quad (\text{semi-circles})$$

$$\psi = \frac{0.0137}{E + 0.11} - 0.022 \quad (\text{semi-circles})$$

$$t = 4.32 * 10^4 \lambda_i + \text{GPS time} \quad (\text{sec})$$

where

$0 \leq t < 86400$: therefore, if $t \geq 86400$ seconds, subtract 86400 seconds;
 if $t < 0$ seconds, add 86400 seconds.

Figure 20-4. Ionospheric Model (Sheet 2 of 3)

The terms used in computation of ionospheric delay are as follows:

- Satellite Transmitted Terms

- | | | |
|------------|---|--|
| α_n | - | the coefficients of a cubic equation representing the amplitude of the vertical delay (4 coefficients - 8 bits each) |
| β_n | - | the coefficients of a cubic equation representing the period of the model (4 coefficients - 8 bits each) |

- Receiver Generated Terms

- | | | |
|-------------|---|--|
| E | - | elevation angle between the user and satellite (semi-circles) |
| A | - | azimuth angle between the user and satellite, measured clockwise positive from the true North (semi-circles) |
| ϕ_u | - | user geodetic latitude (semi-circles) WGS-84 |
| λ_u | - | user geodetic longitude (semi-circles) WGS-84 |
| GPS time | - | receiver computed system time |

- Computed Terms

- | | | |
|-------------|---|--|
| X | - | phase (radians) |
| F | - | obliquity factor (dimensionless) |
| t | - | local time (sec) |
| ϕ_m | - | geomagnetic latitude of the earth projection of the ionospheric intersection point (mean ionospheric height assumed 350 km) (semi-circles) |
| λ_i | - | geodetic longitude of the earth projection of the ionospheric intersection point (semi-circles) |
| ϕ_i | - | geodetic latitude of the earth projection of the ionospheric intersection point (semi-circles) |
| ψ | - | earth's central angle between the user position and the earth projection of ionospheric intersection point (semi-circles) |

Figure 20-4. Ionospheric Model (Sheet 3 of 3)

20.3.4 Timing Relationships. The following conventions shall apply.

20.3.4.1 Paging and Cutovers. At end/start of week (a) the cyclic paging of subframes 1 through 5 shall restart with subframe 1 regardless of which subframe was last transmitted prior to end/start of week, and (b) the cycling of the 25 pages of subframes 4 and 5 shall restart with page 1 of each of the subframes, regardless of which page was the last to be transmitted prior to the end/start of week. Cutovers to newly updated data for subframes 1, 2, and 3 occur on frame boundaries (i.e., Modulo 30 seconds relative to end/start of week). Newly updated data for subframes 4 and 5 may start to be transmitted with any of the 25 pages of these subframes.

20.3.4.2 SV Time vs. GPS Time. In controlling the SVs and uploading of data, the CS shall allow for the following timing relationships:

- a. Each SV operates on its own SV time;
- b. All time-related data in the TLM word and the HOW shall be in SV-time;
- c. All other data in the NAV message shall be relative to GPS time;
- d. The acts of transmitting the NAV message shall be executed by the SV on SV time.

20.3.4.3 Speed of Light. The speed of light used by the CS for generating the data described in the above paragraphs is

$$c = 2.99792458 \times 10^8 \text{ meters per second}$$

which is the official WGS-84 speed of light. The user shall use the same value for the speed of light in all computations.

20.3.4.4 Data Sets. The IODE is an 8 bit number equal to the 8 LSBs of the 10 bit IODC of the same data set. The following rules govern the transmission of IODC and IODE values in different data sets: (1) The transmitted IODC will be different from any value transmitted by the SV during the preceding seven days; (2) The transmitted IODE will be different from any value transmitted by the SV during the preceding six hours. The range of IODC will be as given in Table 20-XII.

Cutovers to new data sets will occur only on hour boundaries except for the first data set of a new upload. The first data set may be cut-in (reference paragraph 20.3.4.1) at any time during the hour and therefore may be transmitted by the SV for less than one hour. During short-term operations, cutover to 4-hour sets and subsequent cutovers to succeeding 4-hour data sets will always occur Modulo 4 hours relative to end/start of week. Cutover from 4-hour data sets to 6-hour data sets shall occur Modulo 12 hours relative to end/start of week. Cutover from 12-hour data sets to 24-hour data sets shall occur Modulo 24 hours relative to end/start of week. Cutover from a data set transmitted 24 hours or more occurs on a Modulo 24-hour boundary relative to end/start of week.

The start of the transmission interval for each data set corresponds to the beginning of the curve fit interval for the data set. Each data set remains valid for the duration of its curve fit interval.

Table 20-XII. IODC Values and Data Set Lengths			
Days Spanned	Transmission Interval (hours) (Note 5)	Curve Fit Interval (hours)	IODC Range (Note 1)
1	2 (Note 4)	4	(Note 2)
2-14	4	6	(Note 2)
15-16	6	8	240-247
17-20	12	14	248-255, 496 (Note 3)
21-27	24	26	497-503
28-41	48	50	504-510
42-59	72	74	511, 752-756
60-87	96	98	757-763
88-122	120	122	764-767, 1008-1010
123-182	144	146	1011-1020

Note 1: For transmission intervals of 6 hours or greater, the IODC values shown will be transmitted in increasing order.

Note 2: IODC values for blocks with 1-, 2- or 4-hour transmission intervals (at least the first 14 days after upload) shall be any numbers in the range 0 to 1023 excluding those values of IODC that correspond to IODE values in the range 240-255, subject to the constraints on re-transmission given in paragraph 20.3.4.4.

Note 3: The ninth 12-hour data set may not be transmitted.

Note 4: Some SVs will have transmission intervals of 1 hour per paragraph 20.3.4.4.

Note 5: The first data set of a new upload may be cut-in at any time and therefore the transmission interval may be less than the specified value.

Normal Operations. The subframe 1, 2, and 3 data sets are transmitted by the SV for periods of two hours. The corresponding curve fit interval is four hours. SVs operating in the Autonav mode will deviate. They will transmit subframe 1, 2, and 3 data sets for periods of one hour. The corresponding curve-fit interval will be four hours.

Short-term and Long-term Extended Operations. The transmission intervals and curve fit intervals with the applicable IODC ranges are given in Table 20-XII.

20.3.4.5 Reference Times. Many of the parameters which describe the SV state vary with true time, and must therefore be expressed as time functions with coefficients provided by the Navigation Message to be evaluated by the user equipment. These include the following parameters as functions of GPS time:

- a. SV time,
- b. Mean anomaly,
- c. Longitude of ascending node,
- d. UTC,
- e. Inclination.

Each of these parameters is formulated as a polynomial in time. The specific time scale of expansion can be arbitrary. Due to the short data field lengths available in the Navigation Message format, the nominal epoch of the polynomial is chosen near the midpoint of the expansion range so that quantization error is small. This results in time epoch values which can be different for each data set. Time epochs contained in the Navigation Message and the different algorithms which utilize them are related as follows:

<u>Epoch</u>	<u>Application Algorithm Reference</u>
t_{oc}	20.3.3.3.3.1
t_{oe}	20.3.3.4.3
t_{oa}	20.3.3.5.2.2 and 20.3.3.5.2.3
t_{ot}	20.3.3.5.2.4

Table 20-XIII describes the nominal selection which will be expressed Modulo 604,800 seconds in the Navigation Message.

The coefficients of expansion are obviously dependent upon choice of epoch, and thus the epoch time and expansion coefficients must be treated as an inseparable parameter set. Note that a user applying current navigation data will normally be working with negative values of $(t-t_{oc})$ and $(t-t_{oe})$ in evaluating the expansions.

The CS will introduce small deviations from the nominal if necessary to preclude possible data set transition ambiguity when a new upload is cut over for transmission. A change from the reference time is used to indicate a change of values in the data set.

Table 20-XIII. Reference Times					
Fit Interval (hours)	Transmission Interval (hours)	Hours After First Valid Transmission Time			
		t_{oc} (clock)	t_{oe} (ephemeris)	t_{oa} (almanac)	t_{ot} (UTC)
4	2*	2	2		
6	4	3	3		
8	6	4	4		
14	12	7	7		
26	24	13	13		
50	48	25	25		
74	72	37	37		
98	96	49	49		
122	120	61	61		
146	144	73	73		
144 (6 days)	144			70	70
144 (6 days)	4080			70	70
* Some SVs will have transmission intervals of 1 hour per paragraph 20.3.4.4.					

20.3.5 Data Frame Parity. The data signal shall contain parity coding according to the following conventions.

20.3.5.1 SV/CS Parity Algorithm. This algorithm links 30-bit words within and across subframes of ten words using the (32,26) Hamming Code described in Table 20-XIV.

20.3.5.2 User Parity Algorithm. As far as the user is concerned, several options are available for performing data decoding and error detection. Figure 20-5 presents an example flow chart that defines one way of recovering data (d_n) and checking parity. The parity bit D_{30}^* is used for recovering raw data. The parity bits D_{29}^* and D_{30}^* , along with the recovered raw data (d_n) are Modulo-2 added in accordance with the equations appearing in Table 20-XIV for $D_{25} \dots D_{30}$, which provide parity to compare with transmitted parity $D_{25} \dots D_{30}$.

Table 20-XIV. Parity Encoding Equations

D_1	=	$d_1 \oplus D_{30}^*$
D_2	=	$d_2 \oplus D_{30}^*$
D_3	=	$d_3 \oplus D_{30}^*$
•		•
•		•
•		•
•		•
D_{24}	=	$d_{24} \oplus D_{30}^*$
D_{25}	=	$D_{29}^* \oplus d_1 \oplus d_2 \oplus d_3 \oplus d_5 \oplus d_6 \oplus d_{10} \oplus d_{11} \oplus d_{12} \oplus d_{13} \oplus d_{14} \oplus d_{17} \oplus d_{18} \oplus d_{20} \oplus d_{23}$
D_{26}	=	$D_{30}^* \oplus d_2 \oplus d_3 \oplus d_4 \oplus d_6 \oplus d_7 \oplus d_{11} \oplus d_{12} \oplus d_{13} \oplus d_{14} \oplus d_{15} \oplus d_{18} \oplus d_{19} \oplus d_{21} \oplus d_{24}$
D_{27}	=	$D_{29}^* \oplus d_1 \oplus d_3 \oplus d_4 \oplus d_5 \oplus d_7 \oplus d_8 \oplus d_{12} \oplus d_{13} \oplus d_{14} \oplus d_{15} \oplus d_{16} \oplus d_{19} \oplus d_{20} \oplus d_{22}$
D_{28}	=	$D_{30}^* \oplus d_2 \oplus d_4 \oplus d_5 \oplus d_6 \oplus d_8 \oplus d_9 \oplus d_{13} \oplus d_{14} \oplus d_{15} \oplus d_{16} \oplus d_{17} \oplus d_{20} \oplus d_{21} \oplus d_{23}$
D_{29}	=	$D_{30}^* \oplus d_1 \oplus d_3 \oplus d_5 \oplus d_6 \oplus d_7 \oplus d_9 \oplus d_{10} \oplus d_{14} \oplus d_{15} \oplus d_{16} \oplus d_{17} \oplus d_{18} \oplus d_{21} \oplus d_{22} \oplus d_{24}$
D_{30}	=	$D_{29}^* \oplus d_3 \oplus d_5 \oplus d_6 \oplus d_8 \oplus d_9 \oplus d_{10} \oplus d_{11} \oplus d_{13} \oplus d_{15} \oplus d_{19} \oplus d_{22} \oplus d_{23} \oplus d_{24}$

Where

d_1, d_2, \dots, d_{24} are the source data bits;

the symbol \star is used to identify the last 2 bits of the previous word of the subframe;

$D_{25}, D_{26}, \dots, D_{30}$ are the computed parity bits;

$D_1, D_2, \dots, D_{29}, D_{30}$ are the bits transmitted by the SV;

\oplus is the "Modulo-2" or "Exclusive-Or" operation.

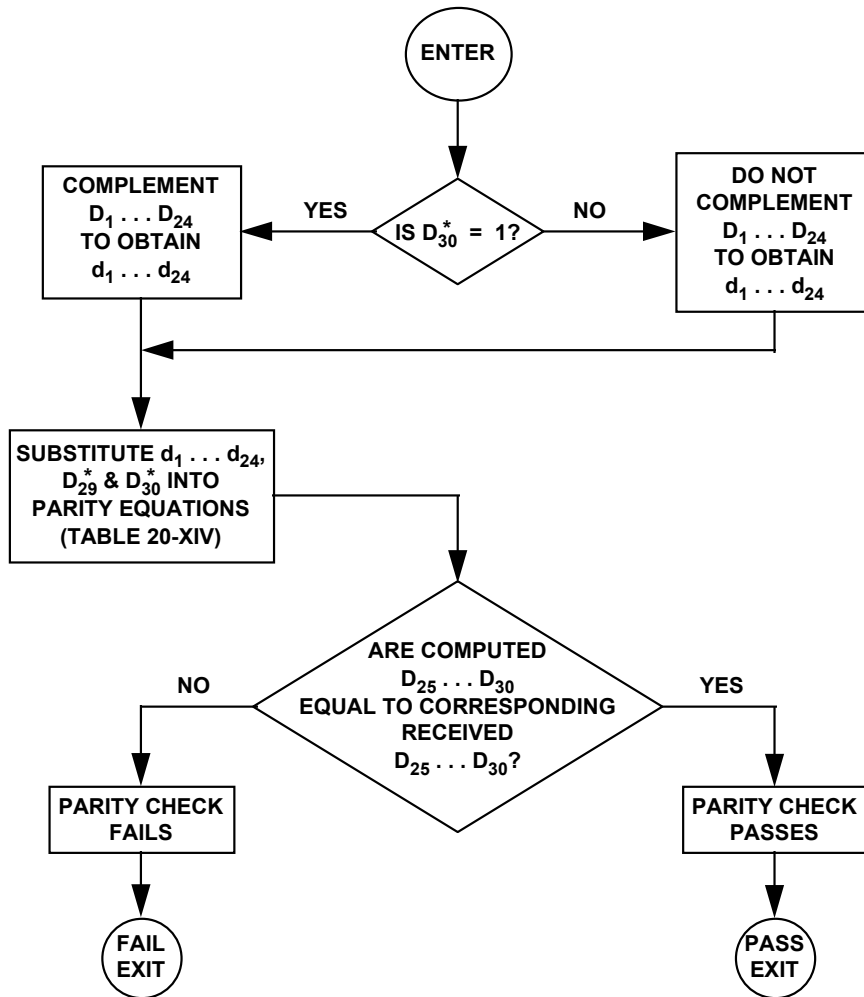

Figure 20-5. Example Flow Chart for User Implementation of Parity Algorithm

UNCLASSIFIED

(This page intentionally left blank.)

**ICD-GPS-200C
10 OCT 1993**

UNCLASSIFIED

30. APPENDIX III. GPS NAVIGATION DATA STRUCTURE FOR L2 CNAV DATA, $D_C(t)$

30.1 Scope. This appendix describes the specific GPS L2 CNAV data structure denoted as $D_C(t)$.

30.2 Applicable Documents.

30.2.1 Government Documents. In addition to the documents listed in paragraph 2.1, the following documents of the issue specified contribute to the definition of the NAV data related interfaces and form a part of this Appendix to the extent specified herein.

Specifications

None

Standards

None

Other Publications

None

30.2.2 Non-Government Documents. In addition to the documents listed in paragraph 2.2, the following documents of the issue specified contribute to the definition of the NAV data related interfaces and form a part of this Appendix to the extent specified herein.

Specifications

None

Other Publications

None

30.3 Requirements

30.3.1 Data Characteristics. The L2 CNAV data stream includes the same data as the L1 and L2 C/A data stream, but in an entirely different format. Also, the L2 CNAV data stream uses a different parity algorithm.

30.3.2 Message Structure. As shown in Figures 30-1 through 30-6, the L2 CNAV message structure utilizes a basic format of twelve-second 300-bit long messages. Each message contains a Cyclic Redundancy Check (CRC) parity block consisting of 24 bits covering the entire twelve-second message (300 bits) (reference Section 30.3.5). At present, only message types 1-6 are defined. Message types 7 through 63 are reserved and message type 0 is the default message. To protect users from message generation failures, the SV shall replace the content of each affected message type with the default message type. In the event that a particular message is not assigned (by the CS) a particular message type for broadcast, the SV shall generate and broadcast the default message type in that message slot.

In addition, Message Types 7 through 9 are presently undefined but are reserved to be used in future broadcast of new clock and ephemeris parameters. The new parameters will be different than the parameters of Message Type 1 and 2, and as such, the related algorithms will also be different than the current equations of Table 20-IV. The initial broadcast of Message Type 1 and 2 will be for test purposes and, as such, will stop and be replaced by Message Type 7 through 9 as soon as the latter message types are fully defined and implemented.

30.3.3 Message Content. Each message starts with an 8-bit preamble – 10001011, followed by a 6-bit PRN number of the transmitting SV, a 6-bit message type ID with a range of 0 (000000) to 63 (111111), and the 17-bit message time of week (TOW) count. When the value of the message TOW count is multiplied by 6, it represents SV time in seconds at the start of the next 12-second message. An “alert” flag, when raised (bit 38 = “1”), indicates to the user that the SV URA may be worse than indicated in Message Type 1, and the SV should be used at the user’s own risk. For each default message (Message Type 0), bits 39 through 276 shall be alternating ones and zeros and the message shall contain a proper CRC parity block.

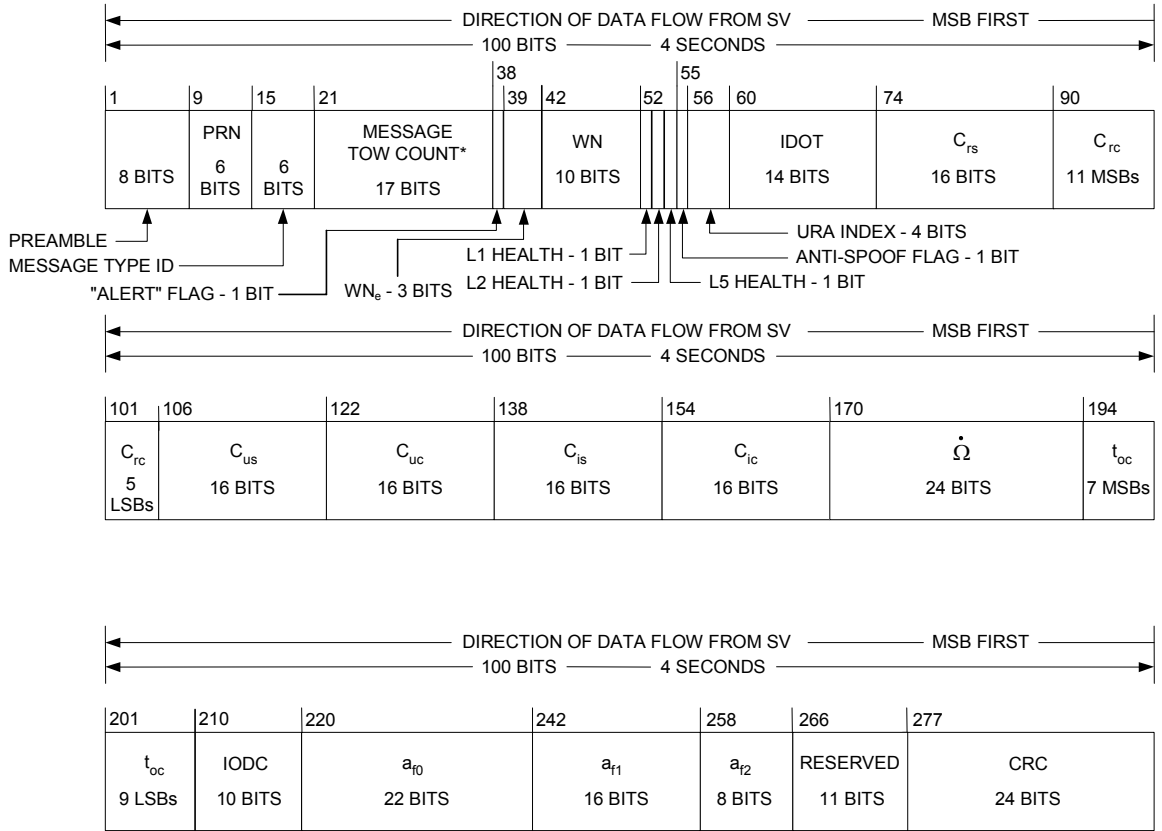

* MESSAGE TOW COUNT = 17 MSBs OF ACTUAL TOW COUNT AT START OF NEXT 12-SECOND MESSAGE

Figure 30-1. Message Type 1 Format

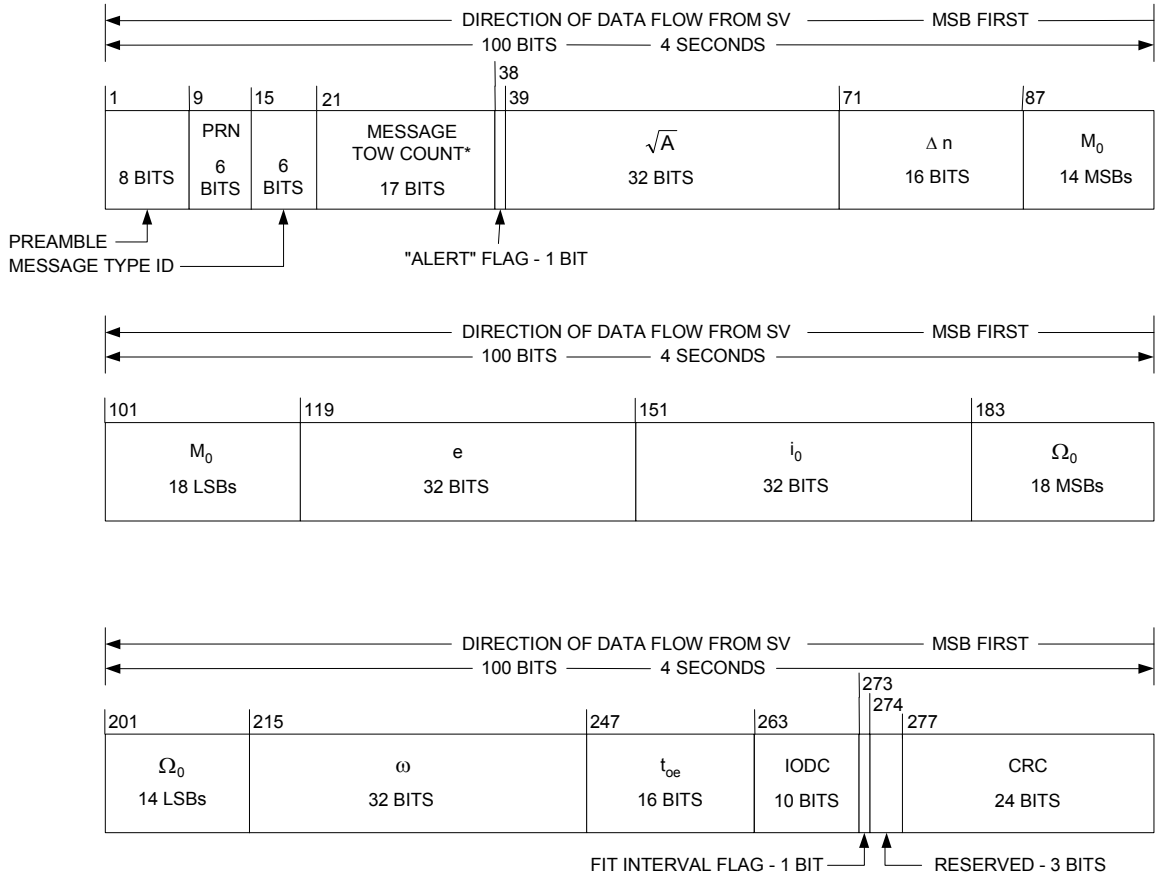

* MESSAGE TOW COUNT = 17 MSBs OF ACTUAL TOW COUNT AT START OF NEXT 12-SECOND MESSAGE

Figure 30-2. Message Type 2 Format

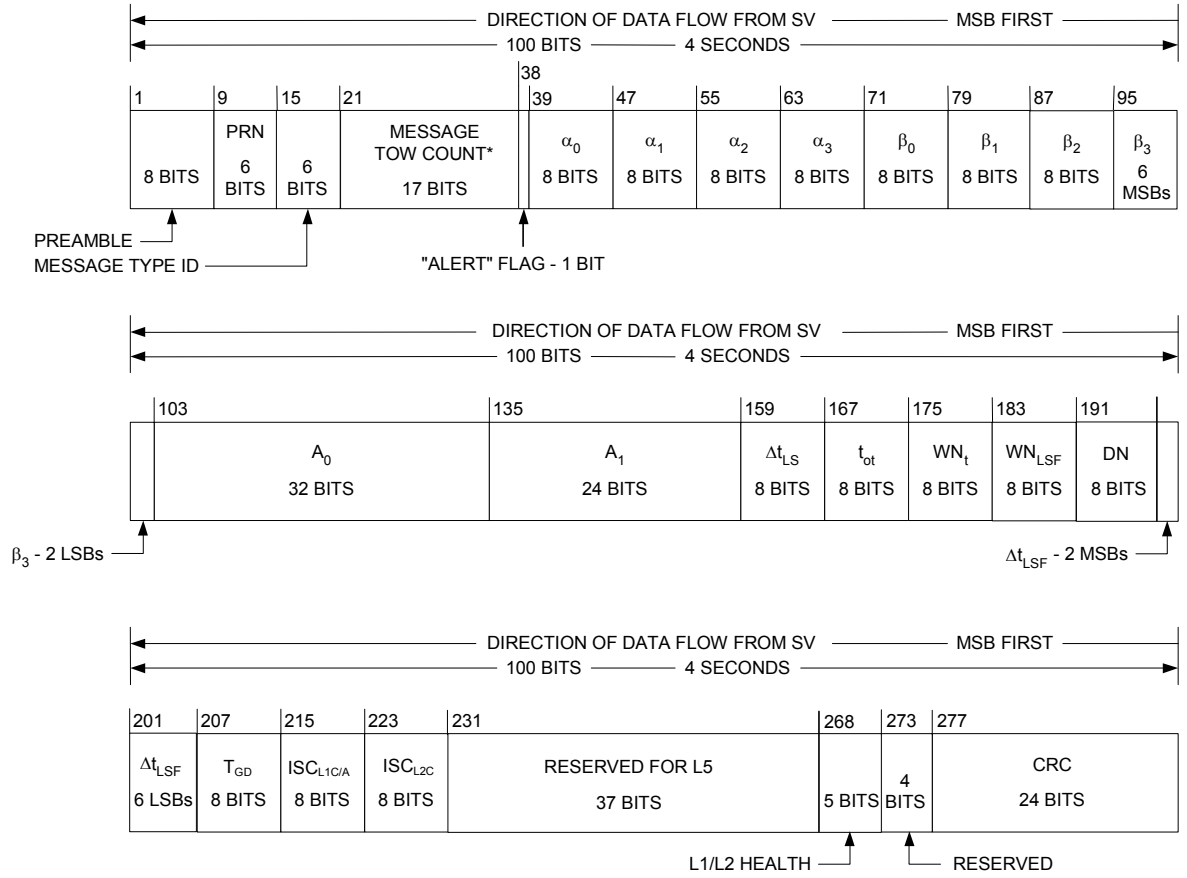

* MESSAGE TOW COUNT = 17 MSBs OF ACTUAL TOW COUNT AT START OF NEXT 12-SECOND MESSAGE

Figure 30-3. Message Type 3 Format

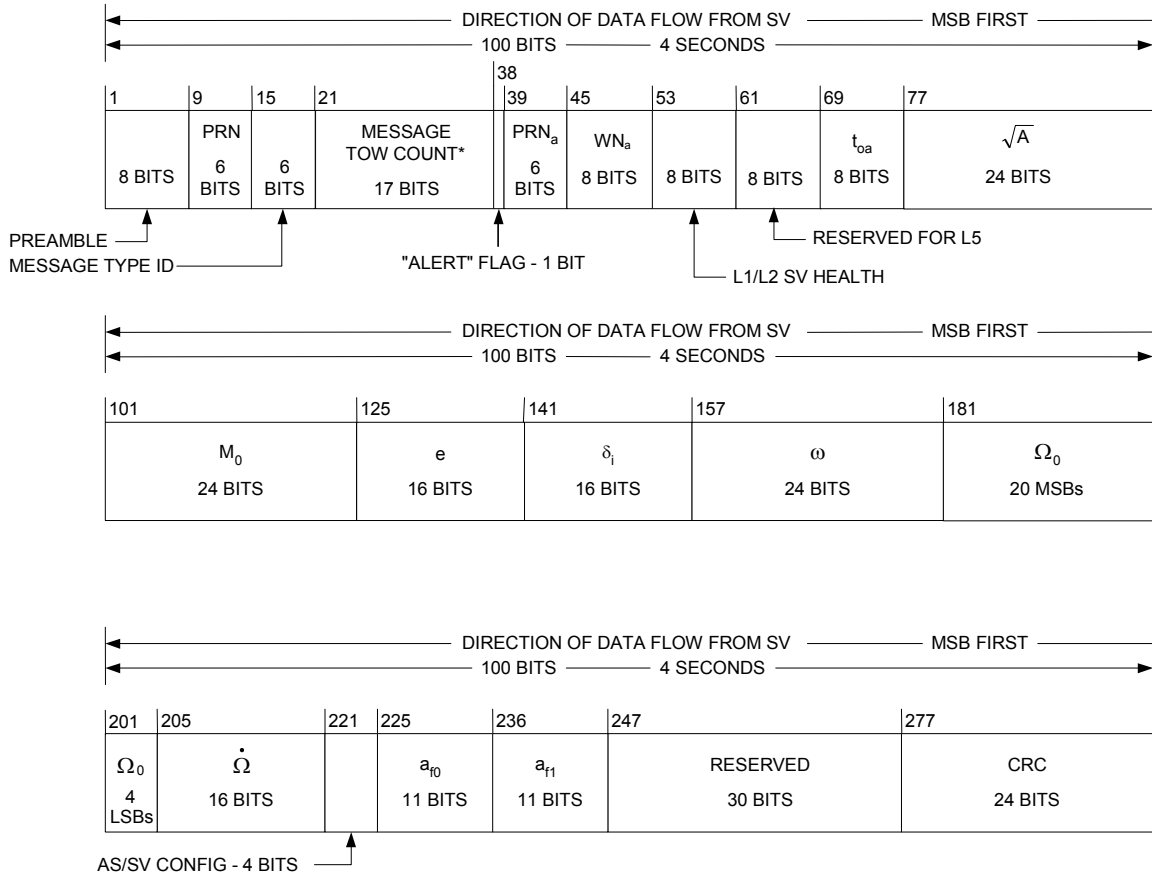

* MESSAGE TOW COUNT = 17 MSBs OF ACTUAL TOW COUNT AT START OF NEXT 12-SECOND MESSAGE

Figure 30-4. Message Type 4 Format

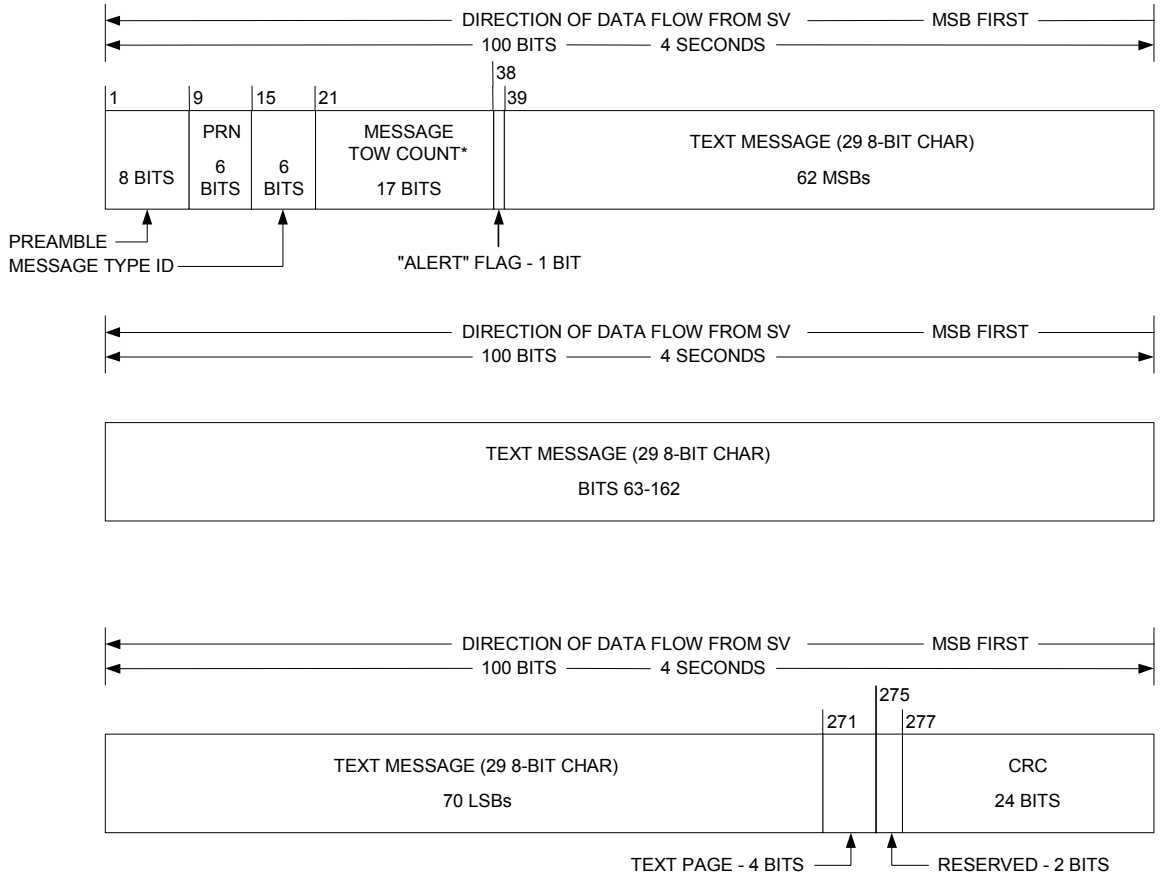

* MESSAGE TOW COUNT = 17 MSBs OF ACTUAL TOW COUNT AT START OF NEXT 12-SECOND MESSAGE

Figure 30-5. Message Type 5 Format

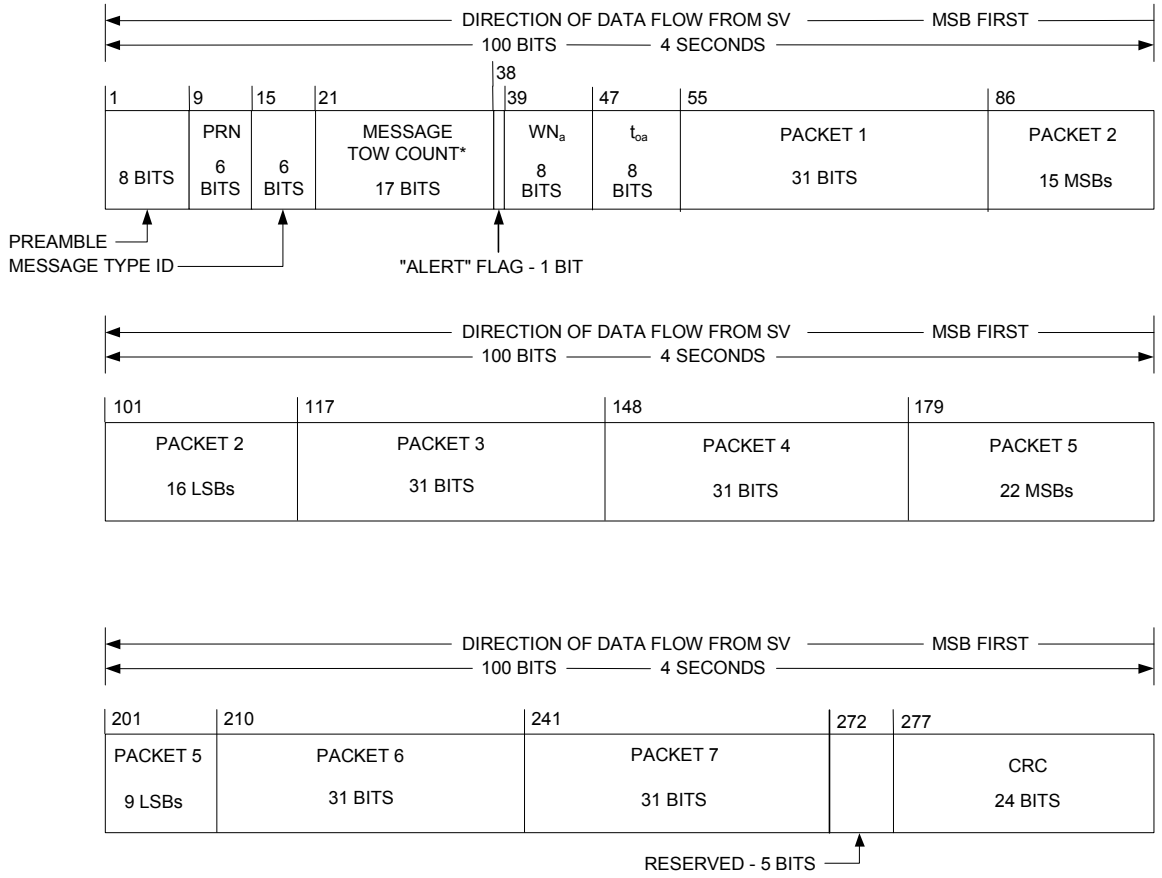

* MESSAGE TOW COUNT = 17 MSBs OF ACTUAL TOW COUNT AT START OF NEXT 12-SECOND MESSAGE

Figure 30-6. Message Type 6 Format

30.3.3.1 Message Type 1 Clock, Health and Accuracy Parameters.

30.3.3.1.1 Message Type 1 Clock, Health and Accuracy Parameter Content. The clock parameters in Message Type 1 describe the SV time scale during the period of validity. The parameters in a data set shall be valid during the interval of time in which they are transmitted and shall remain valid for an additional period of time after transmission of the next data set has started.

30.3.3.1.1.1 Transmission Week Number. Bits 39 through 51 shall contain thirteen bits which are a Modulo 8192 binary representation of the current GPS week number at the start of the data set transmission interval (see paragraph 6.2.4). These thirteen bits are comprised of 10 LSBs (WN) that represent the ten MSBs of the 29-bit Z-count as qualified in paragraph 20.3.3.3.1.1, and 3 MSBs (WN_e) which are three extra bits to extend the range of transmission week number from 10 bits to 13 bits.

30.3.3.1.1.2 SV Accuracy. Bits 56 through 59 shall contain the URA index of the SV (reference paragraph 6.2.1) for the unauthorized (non-Precise Positioning Service) user. The URA index (N) is an integer in the range of 0 through 15 and follows the same rules as defined in paragraph 20.3.3.3.1.3.

30.3.3.1.1.3 Signal Health (L1/L2/L5). The three, one-bit, health indication in bits 52 through 54 refers to the L1, L2, and L5 signals of the transmitting SV. The health of each signal is indicated by,

- 0 = Signal OK,
- 1 = Signal bad or unavailable.

The health indication shall be given relative to the “as designed” capabilities of each SV. Accordingly, any SV that does not have a certain capability will be indicated as “healthy” if the lack of this capability is inherent in its design or if it has been configured into a mode that is normal from a user standpoint and does not require that capability.

The predicted health data will be updated at the time of upload when a new data set has been built by the CS. The transmitted health data may not correspond to the actual health of the transmitted SV.

Additional SV health data are given in Message Types 3, 4, and 6. The data given in Message Type 1 may differ from that shown in other Message Types of the transmitting SV and/or on other SVs since the latter may be updated at a different time.

30.3.3.1.1.4 Issue of Data, Clock (IODC). Bits 210 through 219 shall contain the IODC. The IODC indicates the issue number of the data set and thereby provides the user with a convenient means of detecting any change in the correction parameters. Constraints on the IODC term are defined in paragraph 30.3.4.4.

30.3.3.1.1.4.1 Short-term and Long-term Extended Operations. Whenever the fit interval flag indicates a fit interval greater than 4 hours, the IODC can be used to determine the actual fit interval of the data set (reference section 30.3.4.4).

30.3.3.1.1.5 SV Clock Correction. Message Type 1 contains the parameters needed by the users for apparent SV clock correction (t_{oc} , a_{f2} , a_{f1} , a_{f0}). The related algorithm is given in paragraph 20.3.3.3.1.

30.3.3.1.2 Message Type 1 Clock, Health and Accuracy Parameter Characteristics. For those parameters whose characteristics are not fully defined in Section 30.3.3.1.1, the number of bits, the scale factor of the LSB (which is the last bit received), the range, and the units shall be as specified in Table 30-I.

30.3.3.1.3 User Algorithms for Message Type 1 Clock Data. The algorithms defined in paragraph 20.3.3.3.1 allow all users to correct the code phase time received from the SV with respect to both SV code phase offset and relativistic effects. However, since the SV clock corrections of equations in paragraph 20.3.3.3.1 are estimated by the CS using dual frequency L1 and L2 P(Y) code measurements, the single-frequency L1 or L2 user and the dual frequency L1 C/A - L2 C user must apply additional terms to the SV clock corrections equations. These terms are described in paragraph 30.3.3.1.4.

Table 30-I. Message Type 1 Clock, Health and Accuracy Parameters				
Parameter	No. of Bits**	Scale Factor (LSB)	Effective Range***	Units
Week No.	13	1	604,784	weeks
SV accuracy (URA)	4			(see text)
Signal health (L1/L2/L5)	3	1		(see text)
IODC	10			(see text)
t_{oc}	16	2^4		seconds
a_{f2}	8*	2^{-55}		sec/sec ²
a_{f1}	16*	2^{-43}		sec/sec
a_{f0}	22*	2^{-31}		seconds
* Parameters so indicated are two's complement, with the sign bit (+ or -) occupying the MSB; ** See Figure 30-1 for complete bit allocation in Message Type 1; *** Unless otherwise indicated in this column, effective range is the maximum range attainable with indicated bit allocation and scale factor.				

30.3.3.2 Message Type 1 and 2 Ephemeris Parameters.

30.3.3.2.1 Message Type 1 and 2 Ephemeris Parameter Content. The contents of the ephemeris representation parameters in Message Types 1 and 2 are defined below, followed by material pertinent to the use of the data.

The ephemeris parameters describe the orbit of the transmitting SV during the curve fit intervals described in section 30.3.4. Table 20-II gives the definition of the orbital parameters using terminology typical of Keplerian orbital parameters; it is noted, however, that the transmitted parameter values are expressed such that they provide the best trajectory fit in Earth-Centered, Earth-Fixed (ECEF) coordinates for each specific fit interval. The user shall not interpret intermediate coordinate values as pertaining to any conventional coordinate system.

The issue of data, IODC, term provides the user with a convenient means for detecting any change in the clock and ephemeris representation parameters. The IODC is transmitted in Message Type 1 and 2 for the purpose of comparison of the IODC term between the two message types. Whenever the IODC value in the two message types do not match, a data set cutover has occurred and new data must be collected. The timing and constraints on the IODC are defined in paragraph 30.3.4.4.

Any change in the Message Type 1 and 2 data will be accomplished with a simultaneous change in the IODC word. The CS will assure that the t_{oc}/t_{oe} value, for at least the first data set transmitted by an SV after an upload, is different from that transmitted prior to the cutover.

A “fit interval” flag is provided in Message Type 2 to indicate whether the ephemerides are based on a four-hour fit interval or a fit interval greater than four hours (reference paragraph 30.3.3.2.3.1).

30.3.3.2.2 Message Type 1 and 2 Ephemeris Parameter Characteristics. For each ephemeris parameter contained in Message Types 1 and 2, the number of bits, the scale factor of the LSB (which is the last bit received), the range, and the units are as specified in Table 20-III. See Figures 30-1 and 30-2 for complete bit allocation in Message Types 1 and 2.

30.3.3.2.3 User Algorithm for Ephemeris Determination. The user shall compute the ECEF coordinates of position for the phase center of the SVs' antennas utilizing a variation of the equations shown in Table 20-IV. The ephemeris parameters are Keplerian in appearance; the values of these parameters, however, are produced by the CS via a least squares curve fit of the predicted ephemeris of the phase center of the SVs' antennas (time-position quadruples; t, x, y, z expressed in ECEF coordinates). Particulars concerning the periods of the curve fit, the resultant accuracy, and the applicable coordinate system are given in the following subparagraphs and subsubparagraphs of 20.3.3.4.3.2, 20.3.3.4.3.3, and 20.3.3.4.3.4.

30.3.3.2.3.1 Curve Fit Intervals. Bit 273 of Message Type 2 is a "fit interval" flag which indicates the curve-fit interval used by the CS in determining the ephemeris parameters, as follows:

0 = 4 hours,

1 = greater than 4 hours.

The relationship of the curve-fit interval to transmission time and the timing of the curve-fit intervals is covered in section 30.3.4.

30.3.3.3 Message Type 3 Parameters. The contents of Message Type 3 are defined below, followed by material pertinent to the use of the data.

30.3.3.3.1 Message Type 3 Parameter Content. Message Type 3 contains UTC and ionospheric parameters and other data.

30.3.3.3.1.1 Coordinated Universal Time (UTC) and GPS Time Parameters. Message Type 3 shall contain the parameters related to correlating UTC(USNO) time with GPS Time. The bit length, scale factors, ranges, and units of these parameters are given in Table 20-IX. The related algorithms are described in paragraph 30.3.3.3.2.1.

The parameters relating GPS time to UTC(USNO) shall be updated by the CS at least once every six days while the CS is able to upload the SVs. If the CS is unable to upload the SVs, the accuracy of the UTC parameters transmitted by the SVs will degrade over time.

30.3.3.3.1.2 Ionospheric Data. The ionospheric parameters which allow the “L1 only”, or “L2 only” user to utilize the ionospheric model (reference paragraph 30.3.3.3.2.2) for computation of the ionospheric delay are contained in Message Type 3. The bit lengths, scale factors, ranges, and units of these parameters are given in Table 20-X. See Figure 30-3 for complete bit allocation in Message Type 3.

The ionospheric data shall be updated by the CS at least once every six days while the CS is able to upload the SVs. If the CS is unable to upload the SVs, the ionospheric data transmitted by the SVs may not be accurate.

30.3.3.3.1.3 L1/L2 Health. The five-bit health indication in bits 268 through 272 refers to the L1 and L2 signals of the transmitting SV. The data shall indicate the health of the L1 and L2 signal components in accordance with the codes given in Table 20-VIII.

The predicted health data will be updated at the time of upload when a new data set has been built by the CS. The transmitted health data may not correspond to the actual health of the transmitting SV.

Additional SV health data are given in Message Types 1, 4, and 6. The data given in Message Type 3 may differ from that shown in other Message Types of the transmitting SV and/or on other SVs since the latter may be updated at a different time.

30.3.3.3.1.4 Estimated L1 – L2 Group Delay Differential. The group delay differential correction terms, T_{GD} , $ISC_{L1C/A}$, ISC_{L2C} , for the benefit of single frequency L1 P, L1 C/A, L2 P, L2 C users and dual frequency L1/L2 users is contained in bits 207 through 230 of Message Type 3. The bit length, scale factors, ranges, and units of these parameters are given in Table 30-II. See Figure 30-3 for complete bit allocation in Message Type 3. The bit string of “10000000” shall indicate that the group delay value is not available. The related user algorithms are given in paragraphs 30.3.3.3.2.3 and 30.3.3.3.2.4.

Table 30-II. Group Delay Differential Parameters ****				
Parameter	No. of Bits**	Scale Factor (LSB)	Effective Range***	Units
T_{GD}	8*	2^{-31}		seconds
$ISC_{L1C/A}$	8*	2^{-31}		seconds
ISC_{L2C}	8*	2^{-31}		seconds

* Parameters so indicated are two’s complement with the sign bit (+ or -) occupying the MSB;
 ** See Figure 30-3 for complete bit allocation in Message Type 3;
 *** Effective range is the maximum range attainable with indicated bit allocation and scale factor;
 **** The bit string of “10000000” shall indicate that the group delay value is not available.

30.3.3.3.2 Algorithms Related to Message Type 3 Data. The following algorithms shall apply when interpreting UTC, Ionospheric Model data, and Group Delay Differential data in the L2 CNAV message.

30.3.3.3.2.1 UTC and GPS Time. Message Type 3 includes: (1) the parameters needed to relate GPS Time to UTC(USNO), and (2) notice to the user regarding the scheduled future or recent past (relative to NAV message upload) value of the delta time due to leap seconds (Δt_{LSF}), together with the week number (WN_{LSF}) and the day number (DN) at the end of which the leap second becomes effective. Information required to use these parameters to calculate t_{UTC} is in paragraph 20.3.3.5.2.4.

30.3.3.3.2.2 Ionospheric Model. The “two frequency” (L1 C/A and L2 C) user shall correct the time received from the SV for ionospheric effect by utilizing the time delay differential between L1 and L2 (reference paragraph 30.3.3.3.2.4). The “one frequency” user, however, should use the model given in paragraph 20.3.3.5.2.5 to make this correction.

30.3.3.3.2.3 Inter-Signal Group Delay Differential Correction. The correction terms, $ISC_{L1C/A}$ and ISC_{L2C} , are initially provided by the CS to account for the effect of SV group delay differential between L1 P(Y) and L1 C/A and between L1 P(Y) and L2 C, respectively based on measurements made by the SV contractor during SV manufacture. The values of ISCs for each SV may be subsequently updated to reflect the actual on-orbit group delay differential. For maximum accuracy, the single frequency L1 C/A user must use the correction terms to make further modifications to the code phase offset given by:

$$(\Delta t_{SV})_{L1C/A} = \Delta t_{SV} - T_{GD} + ISC_{L1C/A}$$

where T_{GD} (see paragraph 20.3.3.3.2) and $ISC_{L1C/A}$ are provided to the user as Message Type 3 data, described in paragraph 30.3.3.3.1.4. For the single frequency L2 C user, the code phase offset modification is given by:

$$(\Delta t_{SV})_{L2C} = \Delta t_{SV} - T_{GD} + ISC_{L2C}$$

where, ISC_{L2C} is provided to the user as Message Type 3 data.

The values of $ISC_{L1C/A}$ and ISC_{L2C} are measured values that represent the mean SV group delay differential between the L1 P(Y)-code and the L1 C/A- or L2 C-codes respectively as follows,

$$ISC_{L1C/A} = t_{L1P} - t_{L1C/A}$$

$$ISC_{L2C} = t_{L1P} - t_{L2C}$$

where, t_{Lix} is the GPS time the i^{th} frequency x signal is transmitted from the SV.

30.3.3.3.2.4 L1 /L2 Ionospheric Correction. The two frequency (L1-C/A and L2 C) user shall correct for the group delay and ionospheric effects by applying the relationship:

$$PR = \frac{(PR_{L2C} - \gamma_{12}PR_{L1C/A}) + c (ISC_{L2C} - \gamma_{12}ISC_{L1C/A})}{1 - \gamma_{12}} - c T_{GD}$$

where,

PR = pseudorange corrected for ionospheric effects,
 PR_i = pseudorange measured on the channel indicated by the subscript,
 ISC_i = inter-signal correction for the channel indicated by the subscript (see paragraph 30.3.3.3.2.3),
 T_{GD} = see paragraph 20.3.3.3.2,
 c = speed of light,

and where, denoting the nominal center frequencies of L1 and L2 as f_{L1} and f_{L2} respectively,

$$\gamma_{12} = (f_{L1}/f_{L2})^2 = (1575.42/1227.6)^2 = (77/60)^2.$$

30.3.3.4 Message Type 4 Almanac Parameters. The contents of Message Type 4 are defined below, followed by material pertinent to the use of the data.

30.3.3.4.1 Message Type 4 Almanac Parameter Content. Message Type 4 contains almanac data.

30.3.3.4.1.1 Almanac Data. Message Type 4 contains the almanac data and SV health words for SVs in the constellation. The almanac data are a reduced-precision subset of the clock and ephemeris parameters. The number of bits, the scale factor (LSB), the range, and the units of the almanac parameters are given in Table 20-VI. The algorithms and other material related to the use of the almanac data are given in paragraph 30.3.3.4.2.

The almanac parameters shall be updated by the CS at least once every 6 days while the CS is able to upload the SVs. If the CS is unable to upload the SVs, the accuracy of the almanac parameters transmitted by the SVs will degrade over time.

30.3.3.4.1.2 SV Health (L1 and L2). Message Type 4 contains the eight-bit L1/L2 health words defined in paragraph 20.3.3.5.1.3, Table 20-VII, and Table 20-VIII.

The predicted health data will be updated at the time of upload when a new almanac has been built by the CS. The transmitted health data may not correspond to the actual health of the transmitting SV or other SVs in the constellation.

The data given in Message Types 1, 3, and 6 of the other SVs may differ from that shown in Message Type 4 since the latter may be updated at a different time.

30.3.3.4.1.3 Anti-Spoof (A-S) Flags and SV Configurations. Bits 221 to 224 of Message Type 4 shall contain a four-bit-long term for each operational SV in the constellation to indicate the A-S status (of the L1 and L2 signals) and the configuration code of each SV. The terms are defined in paragraph 20.3.3.5.1.6.

30.3.3.4.1.4 Almanac Reference Week. Bits 45 through 52 of Message Type 4 shall indicate the number of the week (WN_a) to which the almanac reference time (t_{oa}) is referenced (see paragraphs 30.3.3.4.1.1 and 30.3.3.4.2.2). The WN_a term consists of eight bits which shall be a Modulo 256 binary representation of the GPS week number (see paragraph 6.2.4) to which the t_{oa} is referenced. Bits 69 through 76 of Message Type 4 shall contain the value of t_{oa} , which is referenced to this WN_a .

30.3.3.4.1.5 SV PRN Number. Bits 39 through 44 of Message Type 4 shall specify PRN number of the SV whose almanac is provided in the message.

30.3.3.4.2 Algorithms Related to Message Type 4 Data. The following algorithms shall apply when interpreting Almanac data in the NAV message.

30.3.3.4.2.1 Almanac. The almanac is a subset of the clock and ephemeris data, with reduced precision. The user algorithm is essentially the same as the user algorithm used for computing the precise ephemeris from the Message Type 1 and 2 parameters (see paragraph 30.3.3.2.3). The almanac content for one SV is given in Table 20-VI. Important information about the almanac calculation is contained in paragraph 20.3.3.5.2.1.

30.3.3.4.2.2 Almanac Reference Time. See the two subparagraphs labeled Normal and Short-term Extended Operations and Long-term Extended Operations of paragraph 20.3.3.5.2.2.

30.3.3.4.2.3 Almanac Time Parameters. See paragraph 20.3.3.5.2.3.

30.3.3.5 Message Type 5. Message Type 5 is reserved for special messages with the specific contents at the discretion of the Operating Command. It can accommodate the transmission of 29 eight-bit ASCII characters. The requisite 232 bits occupy bits 39 through 270 of Message Type 5. The eight-bit ASCII characters shall be limited to the set described in paragraph 20.3.3.5.1.10.

30.3.3.6 Message Type 6 Reduced Almanac Parameters. The contents of Message Type 6 are defined below, followed by material pertinent to the use of the data.

30.3.3.6.1 Message Type 6 Reduced Almanac Parameter Content. Message Type 6 contains reduced set of almanac data for up to 7 SVs in each 12-second (300-bit) message.

30.3.3.6.1.1 Reduced Almanac Data. Message Type 6 contains the reduced almanac data and SV health words for SVs in the constellation (the health words are discussed in paragraph 30.3.3.1.1.3). The reduced almanac data of a SV is broadcast in a packet of 31 bits in length as described in Figure 30-7. Each Message Type 6 contains 7 packets providing reduced almanac data for up to 7 SVs. The reduced almanac data are a subset of the almanac data which provide less precise ephemeris of which values are provided relative to pre-specified reference values. The number of bits, the scale factor (LSB), the range, and the units of the reduced almanac parameters are given in Table 30-III. The algorithms and other material related to the use of the reduced almanac data are given in paragraph 30.3.3.6.2.

The reduced almanac parameters shall be updated by the CS at least once every 6 days while the CS is able to upload the SVs. If the CS is unable to upload the SVs, the accuracy of the reduced almanac parameters transmitted by the SVs will degrade over time.

30.3.3.6.1.2 Almanac Reference Week. Bits 39 through 46 of Message Type 6 shall indicate the number of the week (WN_a) to which the almanac reference time (t_{oa}) is referenced (see paragraph 30.3.3.6.1.3). The WN_a term consists of eight bits which shall be a Modulo 256 binary representation of the GPS week number (see paragraph 6.2.4) to which the t_{oa} is referenced. Bits 47 through 54 of Message Type 6 shall contain the value of t_{oa} , which is referenced to this WN_a .

30.3.3.6.1.3 Almanac Reference Time. See the two subparagraphs labeled Normal and Short-term Extended Operations and Long-term Extended Operations of paragraph 20.3.3.5.2.2.

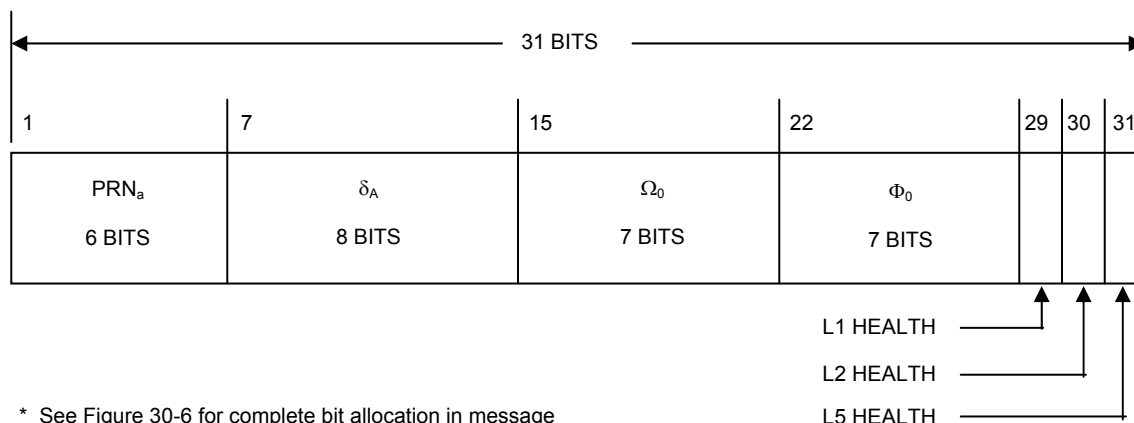

Figure 30-7. Reduced Almanac Packet

Table 30-III. Reduced Almanac Parameters *****				
Parameter	No. of Bits	Scale Factor (LSB)	Effective Range	Units
δ_A ***	8 *	2^{+9}	**	meters
Ω_0	7 *	2^{-6}	**	semi-circles
Φ_0 ****	7 *	2^{-6}	**	semi-circles

* Parameters so indicated shall be two's complement with the sign bit (+ or -) occupying the MSB;

** Effective range is the maximum range attainable with indicated bit allocation and scale factor;

*** Relative to $A_{ref} = 26,559,710$ meters;

**** $\Phi_0 =$ Argument of Latitude at Reference Time = $M_0 + \omega$;

***** Relative to following reference values:

$e = 0$

$\delta_i = +0.0056$ semi-circles ($i = 55$ degrees)

$\dot{\Omega} = -2.6 \times 10^{-9}$ semi-circles/second.

30.3.3.6.2 Reduced Almanac Packet. The following shall apply when interpreting the data provided in each packet of reduced almanac.

30.3.3.6.2.1 SV PRN Number. Bits 1 through 6 in each packet of Message Type 6 shall specify PRN number of the SV whose reduced almanac is provided in the same packet.

30.3.3.6.2.2 Reduced Almanac. The reduced almanac data is provided in bits 7 through 28 of each packet. The data from a packet along with the reference values (see Table 30-III) provide ephemeris with further reduced precision. The user algorithm is essentially the same as the user algorithm used for computing the precise ephemeris from the Message Type 1 and 2 parameters (see paragraph 30.3.3.2.3 and Table 20-IV). Other parameters appearing in the equations of Table 20-IV, but not provided by the reduced almanac with the reference values, are set to zero for SV position determination.

30.3.3.6.2.3 Signal Health (L1/L2/L5). The three, one-bit, health indication in bits 29 through 31 of each packet refers to the L1, L2, and L5 signals of the SV whose PRN number is specified in bits 1 through 6 of the same packet. The signal health indication is described in paragraph 30.3.3.1.1.3.

The predicted health data will be updated at the time of upload when a new reduced almanac has been built by the CS. The transmitted health data may not correspond to the actual health of the transmitting SV or other SVs in the constellation.

The data given in Message Types 1, 3, and 4 of the same or other SVs may differ from that shown in Message Type 6 since the latter may be updated at a different time.

30.3.3.7 Message Type 7 Improved Clock, Health and Accuracy Parameters.

30.3.3.7.1 Message Type 7 Improved Clock, Health and Accuracy Parameters Content. To be Defined.

30.3.3.8 Message Type 7, 8, and 9 Improved Ephemeris Parameters.

30.3.3.8.1 Message Type 7, 8, and 9 Improved Ephemeris Parameters Content. To be Defined.

30.3.4 Timing Relationships. The following conventions shall apply.

30.3.4.1 Paging and Cutovers. Paging of messages is completely arbitrary, but sequenced to provide optimum user performance. Message types 1 and 2 shall be broadcast consecutively.

30.3.4.2 SV Time vs. GPS Time. In controlling the SVs and uploading of data, the CS shall allow for the following timing relationships:

- a. Each SV operates on its own SV time;
- b. All time-related data (TOW) in the messages shall be in SV-time;
- c. All other data in the NAV message shall be relative to GPS time;
- d. The acts of transmitting the NAV messages shall be executed by the SV on SV time.

30.3.4.3 Speed of Light. See paragraph 20.3.4.3.

30.3.4.4 Data Sets. The IODC is a 10 bit value transmitted in Message Type 1 and 2 that indicates the issue number of the data set provided in the two message types. The transmission of IODC value in different data sets shall be such that the transmitted IODC will be different from any value transmitted by the SV during the preceding seven days. The range of IODC will be as given in Table 20-XII.

Cutovers to new data sets follow the rules in the second subparagraph of paragraph 20.3.4.4.

The start of the transmission interval for each data set corresponds to the beginning of the curve fit interval for the data set. Each data set remains valid for the duration of its curve fit interval.

Normal Operations. Message Type 1 and 2 data sets are transmitted by the SV for periods of two hours. The corresponding curve fit interval is four hours.

Short-term and Long-term Extended Operations. The transmission intervals and curve fit intervals with the applicable IODC ranges are given in Table 20-XII.

30.3.4.5 Reference Times. See paragraph 20.3.4.5.

30.3.5 Data Frame Parity. The data signal contains parity coding according to the following conventions.

30.3.5.1 Parity Algorithm. Twenty-four bits of CRC parity will provide protection against burst as well as random errors with a probability of undetected error $\leq 2^{-24} = 5.96 \times 10^{-8}$ for all channel bit error probabilities ≤ 0.5 . The CRC word is calculated in the forward direction on a given message using a seed of 0. The sequence of 24 bits $(p_1, p_2, \dots, p_{24})$ is generated from the sequence of information bits $(m_1, m_2, \dots, m_{276})$ in a given message. This is done by means of a code that is generated by the polynomial

$$g(X) = \sum_{i=0}^{24} g_i X^i$$

where

$$g_i = 1 \quad \text{for } i = 0, 1, 3, 4, 5, 6, 7, 10, 11, 14, 17, 18, 23, 24$$

$$= 0 \quad \text{otherwise}$$

This code is called CRC-24Q (Q for Qualcomm Corporation). The generator polynomial of this code is in the following form (using binary polynomial algebra):

$$g(X) = (1 + X)p(X)$$

where $p(X)$ is the primitive and irreducible polynomial

$$p(X) = X^{23} + X^{17} + X^{13} + X^{12} + X^{11} + X^9 + X^8 + X^7 + X^5 + X^3 + 1$$

When, by the application of binary polynomial algebra, the above $g(X)$ is divided into $m(X)X^{24}$, where the information sequence $m(X)$ is expressed as

$$m(X) = m_k + m_{k-1}X + m_{k-2}X^2 + \dots + m_1X^{k-1}$$

UNCLASSIFIED

The result is a quotient and a remainder $R(X)$ of degree < 24 . The bit sequence formed by this remainder represents the parity check sequence. Parity bit p_i , for any i from 1 to 24, is the coefficient of X^{24-i} in $R(X)$.

This code has the following characteristics:

- 1) It detects all single bit errors per code word.
- 2) It detects all double bit error combinations in a codeword because the generator polynomial $g(X)$ has a factor of at least three terms.
- 3) It detects any odd number of errors because $g(X)$ contains a factor $1+X$.
- 4) It detects any burst error for which the length of the burst is ≤ 24 bits.
- 5) It detects most large error bursts with length greater than the parity length $r = 24$ bits. The fraction of error bursts of length $b > 24$ that are undetected is:

a) $2^{-24} = 5.96 \times 10^{-8}$, if $b > 25$ bits.

b) $2^{-23} = 1.19 \times 10^{-7}$, if $b = 25$ bits.

IRN-200C-005R1
ICD-GPS-200C
14 Jan 2003

(This page intentionally left blank.)

**IRN-200C-005R1
ICD-GPS-200C
14 Jan 2003**